



2F-85

2F-140

Original Notice

© 2020 Robotiq Inc.

Robotiq 2F-85 & 2F-140
for Aubo Robots



Instruction Manual

LEAN 
ROBOTICS
robotiq.com | leanrobotics.org

Table of Contents

1. General Presentation	6
1.1. Gripper nomenclature	7
1.2. 2F-85 vs. 2F-140	8
1.3. Object picking	9
1.4. Setup and control	12
2. Safety	13
2.1. Warning	14
2.2. Intended Use	14
3. Installation	15
3.1. Scope of Delivery	16
3.2. Required Tools and Equipment	17
3.3. Environmental and Operating Conditions	18
3.4. Mechanical Installation	19
3.5. Electrical Setup	24
3.6. Testing the Gripper with the Robotiq User Interface (RUI)	28
4. Control	29
4.1. Overview	29
4.2. Gripper Register Mapping	31
4.3. Robot Output Registers & Functionalities	32
4.4. Robot Input Registers & Status	36
4.5. Picking Features	40
4.6. Control Logic Example	47
4.7. Modbus RTU Communication	48
4.8. Control over Aubo i5	63
5. Specifications	66
5.1. Technical dimensions	67
5.2. Mechanical specifications	74
5.3. Electrical specifications	81
6. Maintenance	82
6.1. Gripper cleaning	84



6.2. Periodic inspection	85
6.3. Fingertip replacement	86
6.4. Overhaul	87
<hr/>	
7. Spare Parts, Kits and Accessories	88
<hr/>	
8. Troubleshooting	92
8.1. Using the Robotiq User Interface (RUI)	92
<hr/>	
9. Warranty and Patent	93
<hr/>	
10. Harmonized Standards, Declarations and Certificates	95
10.1. Translation of original EC declaration of incorporation	95
10.2. Applied standards	96
<hr/>	
11. Contact	97



Revisions

Robotiq may modify this product without notice, when necessary, due to product improvements, modifications or changes in specifications. If such modification is made, the manual will also be revised, see revision information. See the latest version of this manual online at support.robotiq.com.

Revision 2020/02/11

Multiple modifications to standardize with our other manuals

Revision 2019/10/10

Addition of the Electrostatic Discharge Safety section

Revision 2019/05/17

Environmental and Operating Conditions updated.

Revision 2019/02/10

General Presentation section updated.

Revision 2019/04/02

First Publication of Instruction Manual



Copyright

© 2016-2020 Robotiq Inc. All rights reserved.

This manual and the product it describes are protected by the Copyright Act of Canada, by laws of other countries, and by international treaties, and therefore may not be reproduced in whole or in part, whether for sale or not, without prior written consent from Robotiq. Under copyright law, copying includes translation into another language or format.

Information provided by Robotiq in this document is believed to be accurate and reliable. However, no responsibility is assumed by Robotiq for its use. There may be some differences between the manual and the product if the product has been modified after the edition date.

The information contained in this document is subject to change without notice.



1. General Presentation

The terms "Gripper", "Adaptive Gripper", "Robotiq Gripper", "Robotiq Adaptive Gripper", "2-Finger 85", "2-Finger 140", "2F-85" and "2F-140" used in the following manual all refer to the Robotiq 2-Finger Adaptive Robot Gripper. The Robotiq 2-Finger Adaptive Gripper has two versions, 85 and 140. The 2-Finger version will change finger opening dimensions, which will be 85 mm (2F-85) or 140 mm (2F-140). Both versions use the same base, installation and control will be exactly the same. The 2-Finger Gripper is a robotic peripheral that is designed for industrial applications. Its design makes it a unique robotic end-of-arm tool to quickly pick, place, and handle a large range of objects of varying sizes and shapes.

Info

Unless specified, information in this manual applies to both the 85 and the 140 mm version of the 2-Finger Adaptive Gripper.

Info

The following manual uses the metric system, unless specified, **all dimensions are in millimeters**.

Info

The following section presents the key features of the Gripper and must not be considered as appropriate to Gripper operation, each feature is detailed in the appropriate section of the manual. Safety guidelines must be read and understood before any operation is attempted with the Gripper.



1.1. Gripper nomenclature

The 2-Finger Gripper has two articulated fingers that each have two joints (two phalanxes per finger), as shown in the figure below. The grasp-type gripper can engage up to five points of contact with an object (two on each of the phalanges plus the palm). The fingers are under-actuated, meaning they have fewer motors than the total number of joints. This configuration allows the fingers to automatically adapt to the shape of the object they grasp which simplifies the control of the gripper.

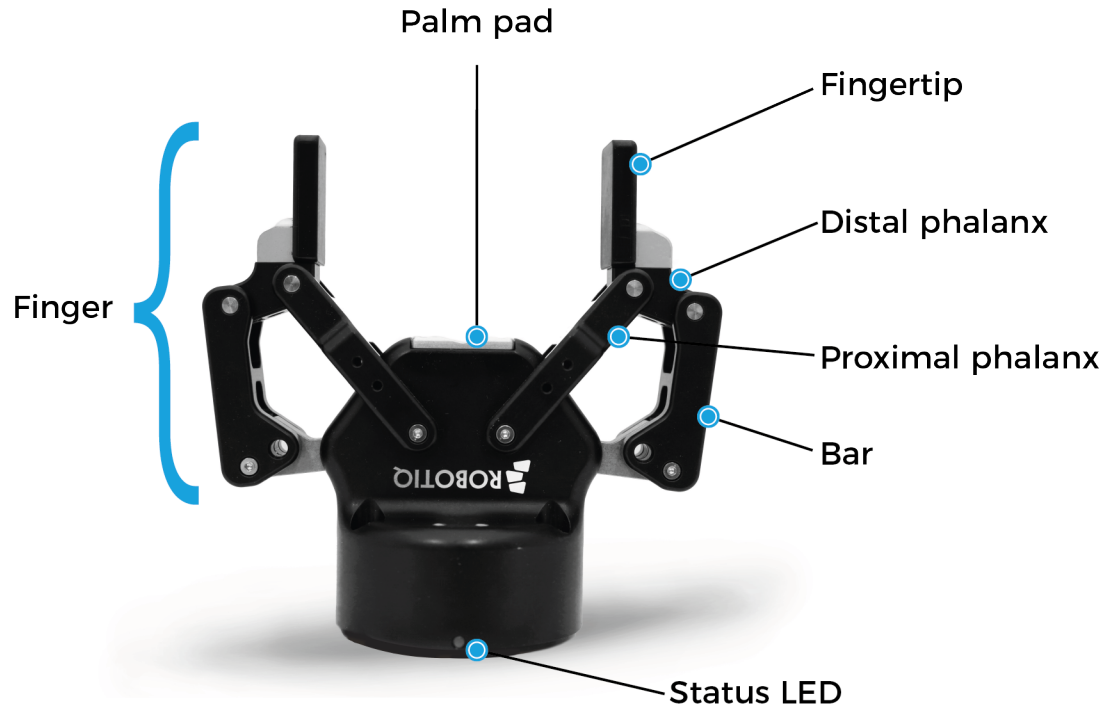

Fig. 1-1: Robotiq 2-Finger Adaptive Gripper.

Please refer to the **Spare Parts, Kits and Accessories** section for details on standard and optional parts.

The status LED presented in the figure above will be :

- solid blue/red when booting
- solid blue when powered with no errors (while communication is active)
- solid red if minor fault occurs, see status details in the **Control** section.
- blinking red/blue if major fault occurs, see status details in the **Control** section.

1.2. 2F-85 vs. 2F-140

The 2-Finger Gripper has two configurations either 85 mm opening (2-Finger 85) or 140 mm opening (2-Finger 140). The chassis remains the same, only the fingers will change. Please refer to the **Mechanical Installation** section for installation instructions. Finger kits are available in the **Spare Parts, Kits and Accessories** section.

Info

Details on the 2-Finger 85 and 2-Finger 140 (dimensions and specifications) can be found in the **Specifications** section.

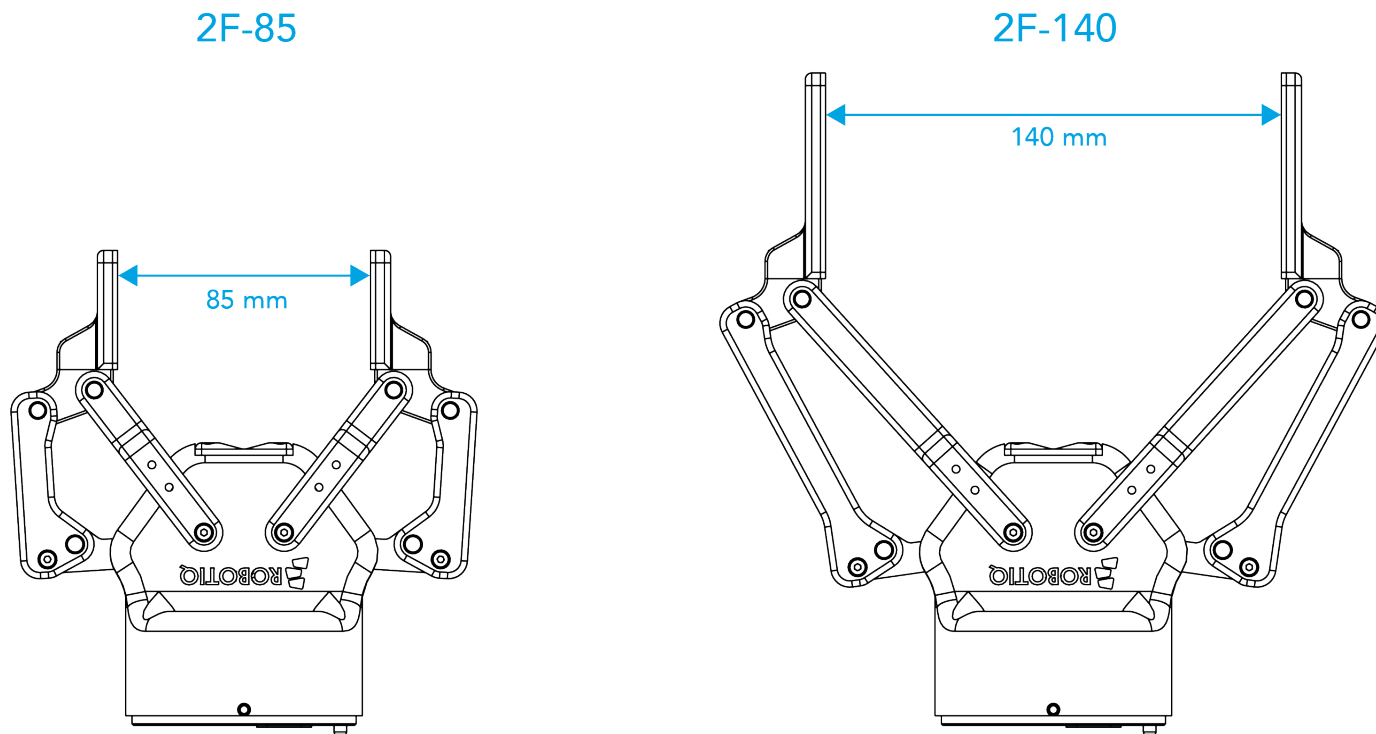

Fig. 1-2: The 2-Finger 85 and 140 mm versions.



1.3. Object picking

The 2-Finger Gripper has a single actuator for opening and closing the fingers. The fingers automatically adapt to the shape of the object manipulated.

Fingers will adopt either a parallel grasp or encompassing grasp as shown in the figure below.

Info

Closing or opening is done via the "Go to requested position" command sent to the gripper. **Whether the fingers close to produce an encompassing or parallel grasp is determined mechanically by:**

- The object's geometry;
- The relative position of the object with respect to the gripper.

In other words, picking the same object could result in either an encompassing or fingertip grasp based on an object's position and geometry.

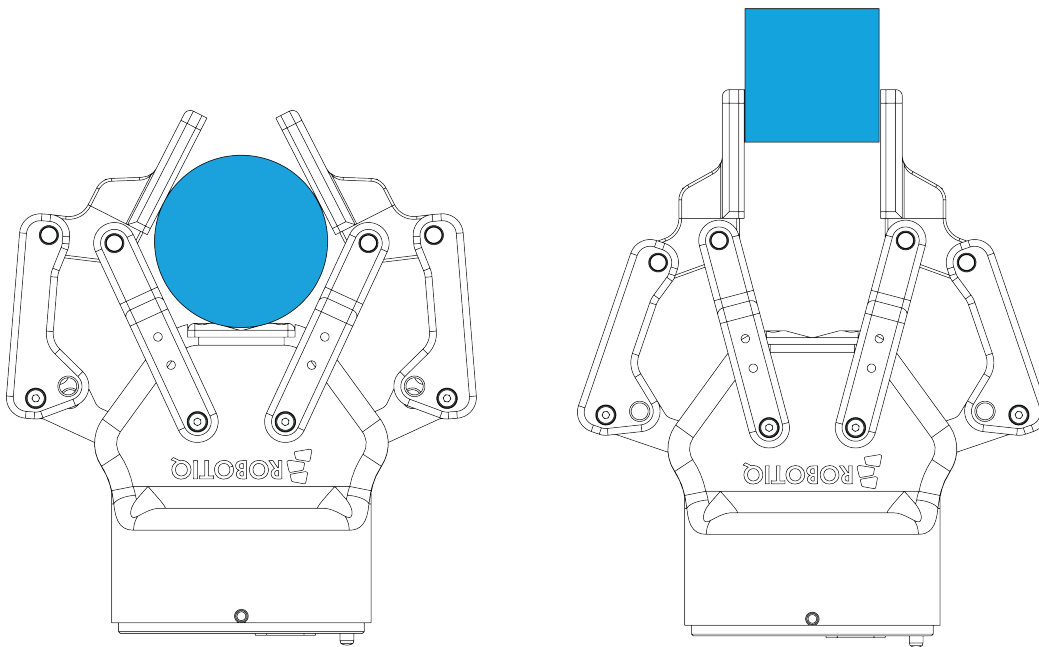

Fig. 1-3: 2-Finger parallel and encompassing grips.

Info

It is important to note that a fingertip grasp can only be performed when the fingers touch the object with the upper section of the distal phalanges first. Inversely, for an encompassing grip, the fingers must touch the object with the proximal or the lower section of the distal phalanges first. Also, to ensure stability, the object should be held against the gripper palm while performing an encompassing grip. Refer to Fig. 1-5 for a visual representation of the parallel and encompassing grasp regions on the distal phalanx of the 2-Finger Gripper.



The 2-Finger Adaptive Gripper also allows for internal grasping. The fingers can pick hollow objects from the inside by applying pressure with the outside of the fingers. Refer to the figure below for a visual representation and to the **Picking Features** section for details on the possible position commands of your gripper.

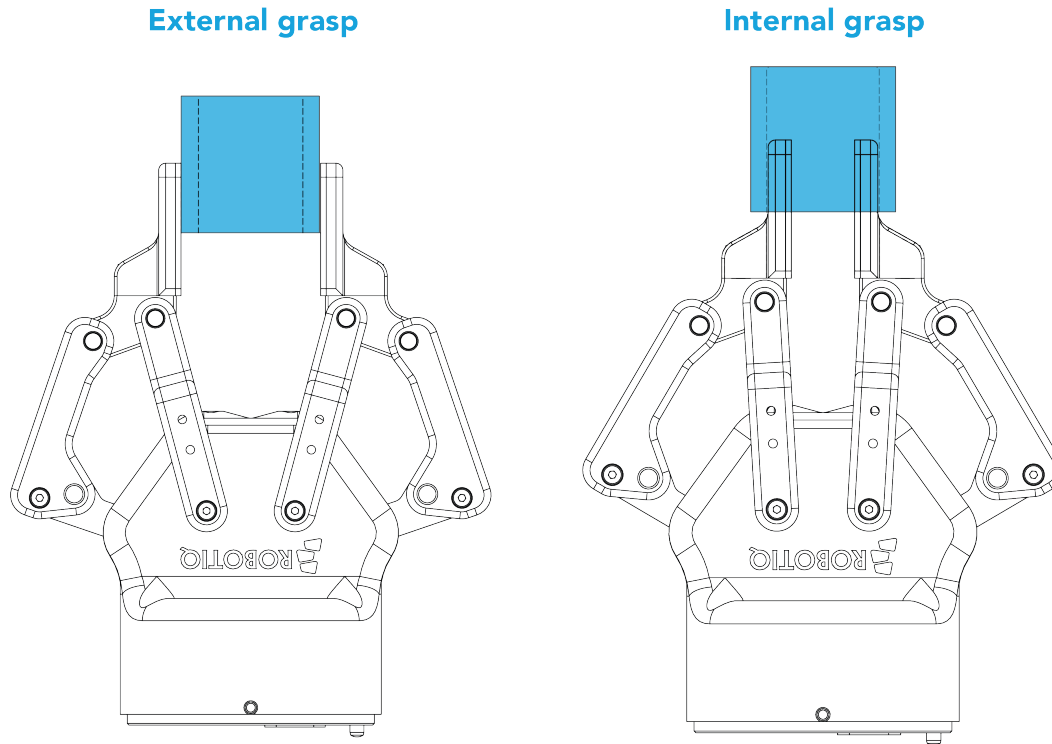

Fig. 1-4: Finger internal and external grasping.

The gripper equilibrium line is the grasping region that separates the encompassing grasp from the parallel grasp. When grasping an object close enough to the inside (palm) of the gripper, the encompassing grasp will occur (unless the object size or shape is not adequate) and the fingers will close around the object.

If grasped above the equilibrium line, the same object will be picked up in a parallel grasp by the fingertips and the fingers will close with a parallel motion. The figure below shows the **encompassing grasp region**, the **equilibrium line**, and the **parallel grasp region** on the 2-Finger Adaptive Gripper.

Info

The details of the equilibrium line relation between opening angle and the related position d can be found in the **Mechanical specifications** section.

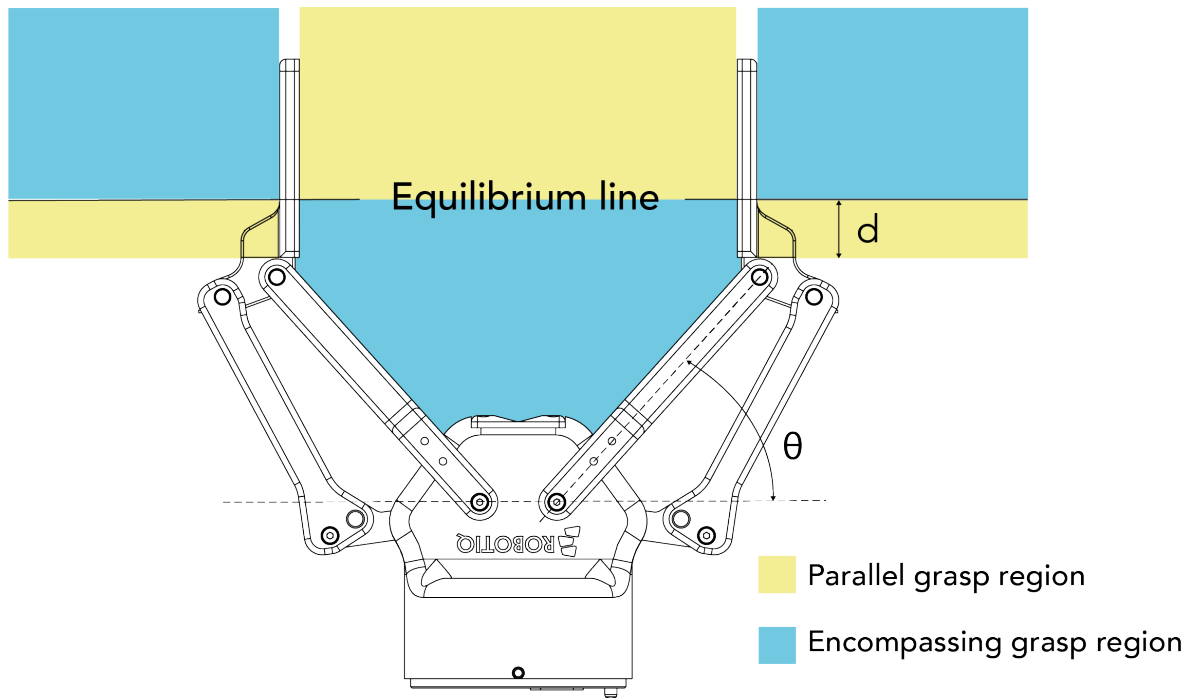

Fig. 1-5: Equilibrium line on the 2-Finger.

Tip

Grasping an object that could be grasped by an encompassing grasp (a cylinder for example) on the equilibrium line is not recommended, as slight variations on the position will switch the grasp from parallel to encompassing and vice versa. Robot programming should be done so that the grasping mode will be predetermined.

1.4. Setup and control

The gripper is powered and controlled directly via a single device cable that carries a 24V DC supply and Modbus RTU communication over RS-485. Refer to the **Electrical Setup** section for wiring information and the **Control** section for control of the gripper (various software packages are available for control via various robot controllers).

Info

Robotiq Universal Controller is available when industrial communication protocols are required (other than Modbus RTU).

A gripper coupling is required for using 2-Finger, the coupling will provide mechanical and electrical connectivity. Please refer to the **Mechanical Installation** section for installation of the coupling, to the **Specifications** section for technical drawings, and to the **Spare Parts, Kits and Accessories** section for available couplings.

The 2-Finger has an embedded object detection feature using indirect sensing methods. When picking an object via the "go to" command, the gripper status will allow you to know if an object is picked or not via a simple object detection bit (0 or 1). When an object is detected, the gripper will stop. If the object is being dropped, the gripper will automatically close to keep the object until the object is detected or until the position target from the "go to" command is reached. For details on object detection, see **Control** section.



2. Safety

Warning

The operator must have read and understood all of the instructions in the following manual before handling the Robotiq 2-Finger Adaptive Robot Gripper.

Caution

The term "operator" refers to anyone responsible for any of the following operations on the 2-Finger Adaptive Robot Gripper:

- Installation
- Control
- Maintenance
- Inspection
- Calibration
- Programming
- Decommissioning

This documentation explains the various components of the 2-Finger and general operations regarding the whole life-cycle of the product from installation to operation and decommissioning.

The drawings and photos in this documentation are representative examples nonetheless, discrepancies may be observed between those and the delivered product.



2.1. Warning

Caution

Any use of the Gripper in noncompliance of these warnings is inappropriate and may cause injury or damage.

Warning

- The Gripper needs to be properly secured before operating the robot.
- Do not install or operate a Gripper that is damaged or lacking parts.
- Never supply the Gripper with an alternative current source.
- Make sure all cord sets are always secured at both ends, at the Gripper and at the robot.
- Always meet the recommended keying for electrical connections.
- Make sure no one is in the robot and/or Gripper path before initializing the robot's routine.
- Always meet the Gripper's payload specifications.
- Set the Gripper's pinch force and speed accordingly, based on your application.
- Keep fingers and clothes away from the Gripper while the power is on.
- Do not use the Gripper on people or animals.
- For welding applications, make sure there are no Gripper parts on the ground path of the welding power source.

2.1.1. Risk assessment and final application:

The Robotiq 2-Finger Adaptive Gripper is meant to be used on an industrial robot. The robot, Gripper, and any other equipment used in the final application must be evaluated with a risk assessment. It is the robot integrator's duty to ensure that all local safety measures and regulations are met. Depending on the application, there may be risks that require additional protection/safety measures, for example, the work-piece the gripper is manipulating might be inherently dangerous to the operator.

2.2. Intended Use

The gripper unit is designed for grasping and temporarily securing or holding objects.

The product is intended for installation on a robot or other automated machinery and equipment.

Info

Always comply with local and/or national laws, regulations and directives on automation safety and general machine safety.

The unit should be used exclusively within the range of its technical data. Any other use of the product is deemed improper and unintended use. Robotiq will not be liable for any damages resulting from any improper or unintended use.



3. Installation

The following subsections will guide you through the installation and general setup of your Robotiq 2-Finger Adaptive Gripper.

- The **Scope of Delivery** section
- The **Required Tools and Equipment** section
- The **Environmental and Operating Conditions** section
- The **Mechanical Installation** section
- The **Electrical Setup** section
- The **Testing the Gripper with the Robotiq User Interface (RUI)** section

Warning

Before installing:

- Read and understand the safety instructions related to the 2-Finger Adaptive Gripper.
- Verify your package according to the Scope of delivery and your order.
- Have the required parts, equipment and tools listed in the requirements readily available.

Warning

When installing:

- Meet the recommended environmental conditions.
- Do not operate the Gripper, or even turn on the power supply, before it is firmly anchored and the danger zone is cleared. The fingers of the gripper may move and cause injury or damage.



3.1. Scope of Delivery

Caution

The following is not included as part of a standard delivery:

- Options such as adapter plates or couplings for mounting on various industrial robots, fingertips.
- Hardware required for options; accessories or fixtures for the gripper, unless specified.
- Power supply units, power supply wiring or fuses.

Info

When bought as a kit, the gripper will come in a package with the appropriate coupling, fingers/fingertips and cabling. Please refer to the **Spare Parts, Kits and Accessories** section.

3.1.1. Aubo Kit

AGC-AUBO-KIT-85 / AGC-AUBO-KIT-140

- Robotiq 2F basic gripper unit (GRIPPER-2F85 / GRIPPER-2F140)
- Coupling for connection to the robot controller (GRP-CPL-062)
- Robotiq device cable (CBL-COM-2065-10-HF)
- USB to RS485 converter (ACC-ADT-USB-RS485)
- USB stick
- Screw kit



3.2. Required Tools and Equipment

The following tools are required to install the 2-Finger Adaptive Gripper:

- 4 mm hex key to mount the gripper onto its coupling.
- Metric hex key according to your coupling to mount the coupling onto the robot.

Optional tools if installing finger kits: **AGC-FIN-KIT-085** or **AGC-FIN-KIT-140**:

- 2 mm hex key

Optional tools if installing other fingertips: **AGC-TIP-MLD-KIT-85**, **AGC-TIP-MLD-140**, **AGC-TIP-204-085**, **AGC-TIP-205-085**, **AGC-TIP-420-140**, **AGC-TIP-421-140**

- 4 mm hex key

The gripper needs to be supplied by a DC voltage source. This power supply is not included with the gripper. Required power supply must match the Robotiq device. The following table shows the specifications with regards to the power supply required to operate the gripper and the optional Robotiq Controller.

SPECIFICATION	VALUE
Output voltage	24 V DC \pm 10%
Output current	1 A
Overcurrent	Recommended power supply with internal protection, otherwise fusing is required. 2 A fuse at 25°C [77°F] ¹

Table 3-1: 2-Finger power supply requirements.

Info

¹ Suggested fuse is a: Phoenix Contact # 0916605 2 A thermal, use AWG #20 wiring.

Warning

If your power supply could exceed the specified regulation, over-voltage protection is required.

Robotiq recommends the use of the following power supplies:

- For the 1A output current: TDK-Lambda DPP Series, 100W Single Output DIN Rail Mount Power Supply: **DPP30-24**.

Tip

Optional Robotiq Universal Controller can use the same power supply.



3.3. Environmental and Operating Conditions

CONDITION	VALUE
Minimum storage/transit temperature	-30°C [-22°F]
Maximum storage/transit temperature	70°C [158°F]
Minimum operating temperature	-10°C [14°F]
Maximum operating temperature	50°C [122°F]
Humidity (non-condensing)	20-80% RH
Maximum vibration (storage/transit)	5G
Maximum vibration (operating)	2G
IP Rating	IP 40
Other	<ul style="list-style-type: none"> • Free from dust, soot or fluids • Free from corrosive liquids or gases • Free from explosive liquids or gases • Free from powerful electromagnetic interference

Table 3-2: Environmental and operating conditions of the 2-Finger Adaptive Gripper



3.4. Mechanical Installation

3.4.1. Installing the Gripper on the robot

Single Gripper Installation

Here are the steps to follow to mount the gripper to your robot with the **Standard Coupling Kit**.

1. Screw the adapter plate (if adapter plate is required).
2. Screw the coupling to the robot.
3. Screw the gripper onto its coupling.

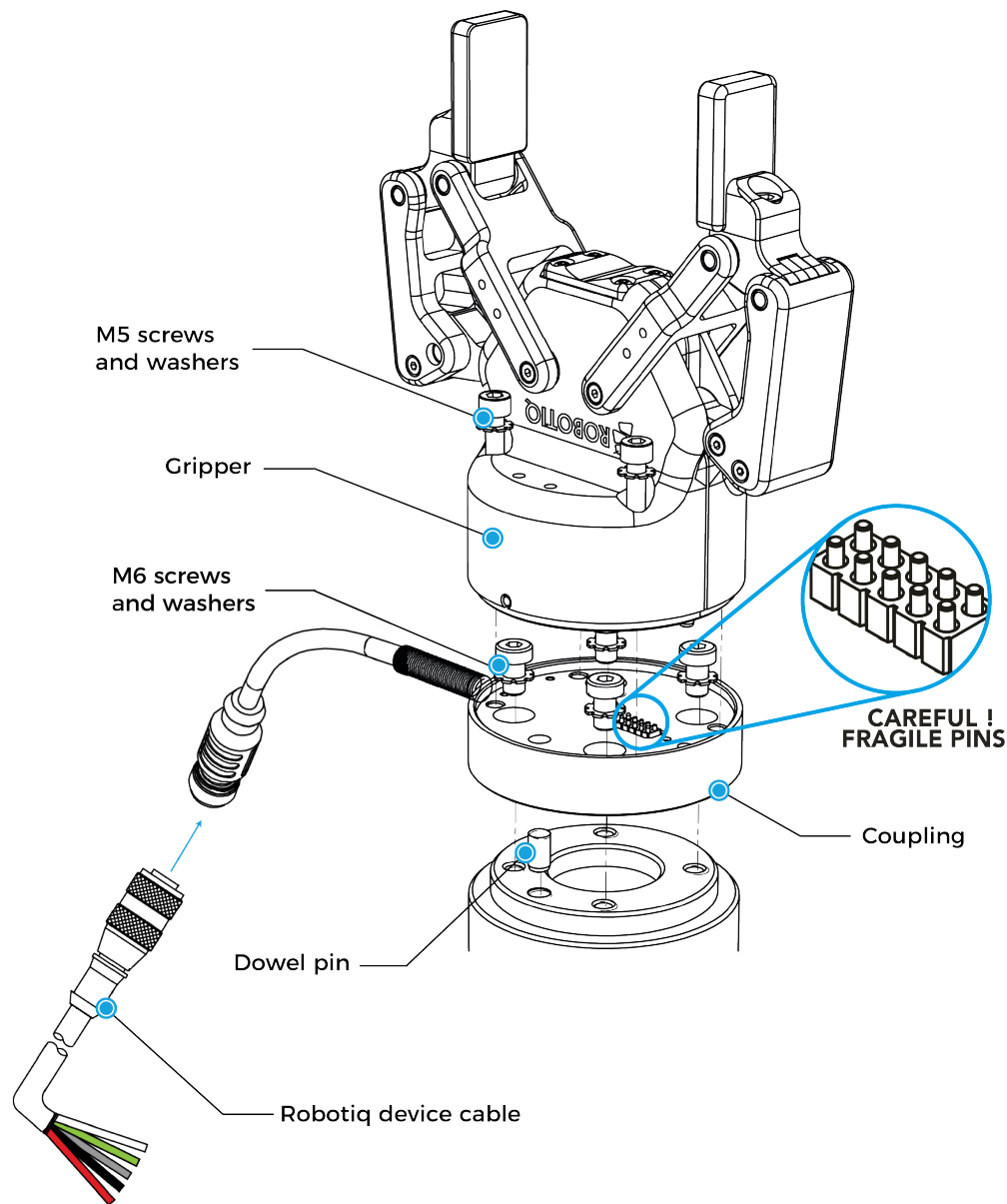

Fig. 3-1: Installing the Gripper on a robot wrist



Multiple Grippers Installation

When installing multiple grippers on one robot, every gripper must have its own coupling.

1. Install a mounting plate first on the robot arm (AGC-APL-159-02).
2. Mount the grippers' couplings on the mounting plate using the provided M6 X 12 mm screws and tooth lock washers.
3. Mount the grippers onto the coupling using the provided M5 X 25 mm screws and tooth lock washers.

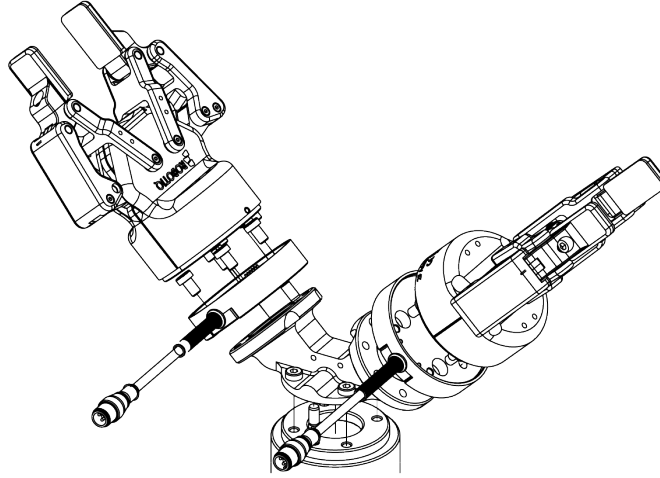

Fig. 3-2: Dual 2F Gripper Configuration

3.4.2. Installing Fingers on the Gripper

If you need to change the fingers, follows the instructions below.

1. Align finger with chassis axis. To do so, the holes on the bar and the proximal should be aligned correctly with the corresponding chassis axis.
2. Insert the bar axis in the bar hole and through the chassis axis (top hole is for parallel locking while bottom hole is for finger installation).
3. Insert the proximal axis in the holes located on the proximal and through the chassis axis.
4. Apply medium strength threadlocker on the provided screws and secure the finger to the chassis.
5. Repeat for the other finger.

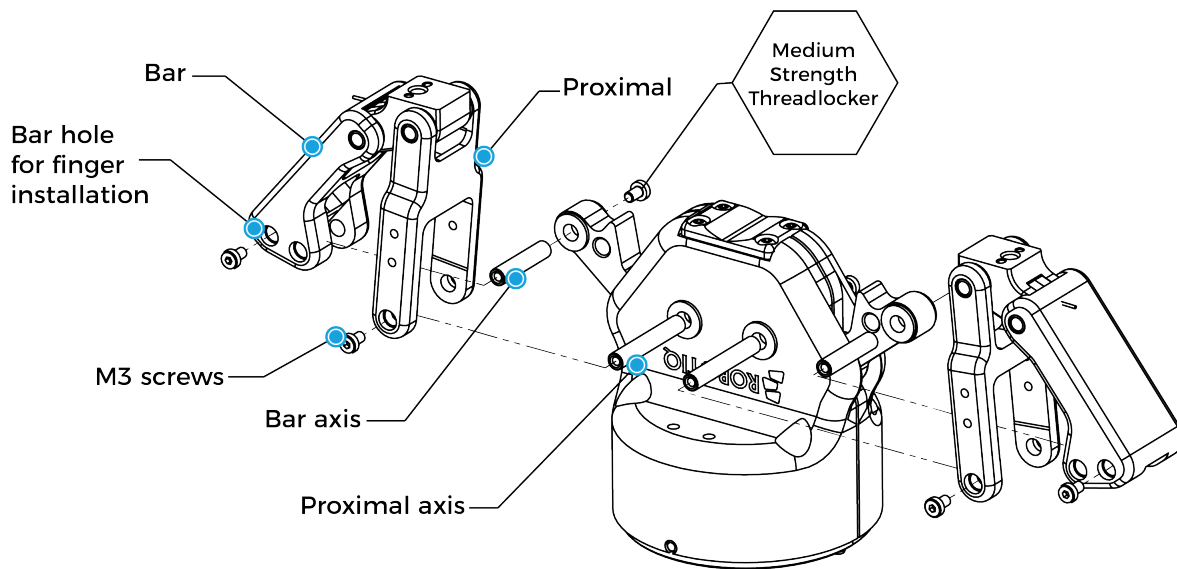

Fig. 3-3: Installing the Fingers on the Gripper.



3.4.3. Installing the fingertips on the Gripper

If you need to change the fingertips, follow the instructions below.

1. Align the fingertip dowel pins with the finger dowel holes.
2. Apply low strength threadlocker on the provided screws and secure the fingertips to the fingers.

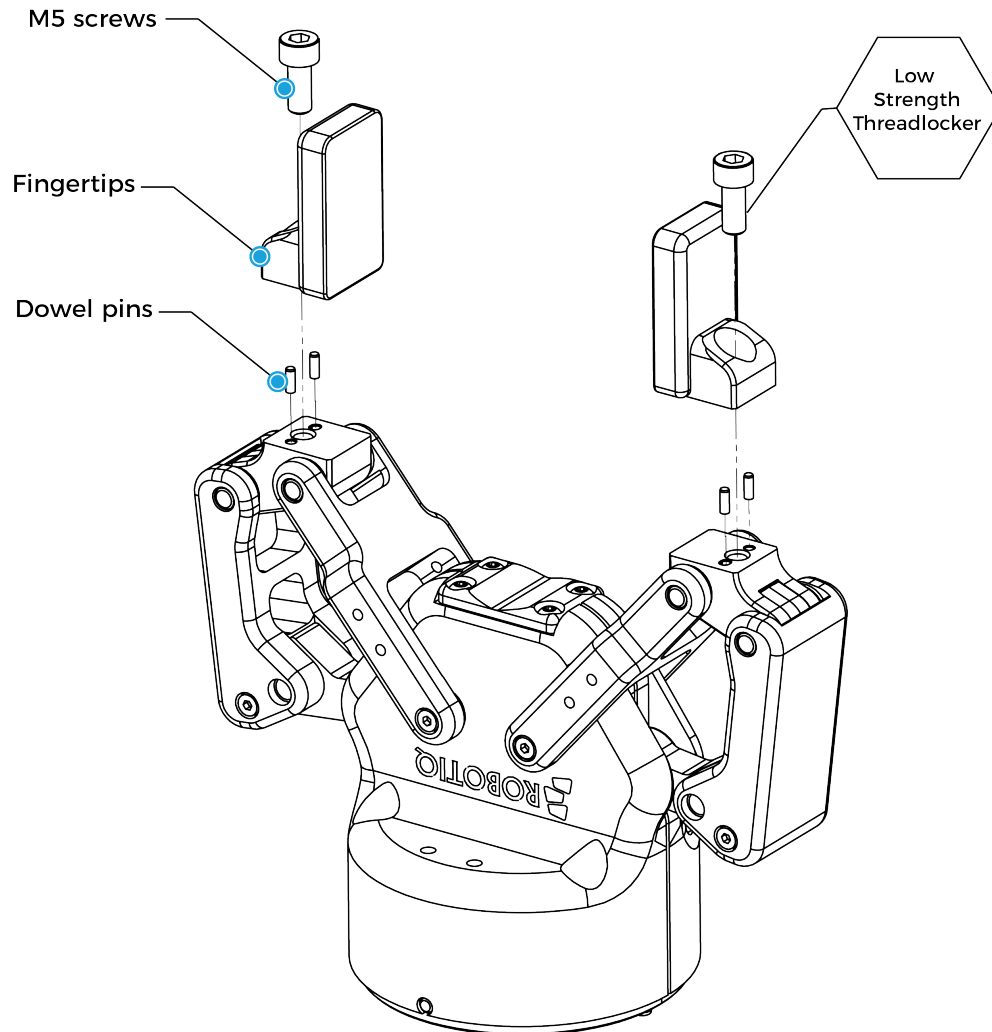

Fig. 3-4: Installing the Fingertips on the Gripper.

3.4.4. Installing a Protector Kit on the Gripper Fingers

An optional protector kit (AGC-PRO-KIT-V4 / AGC-PRO-KIT-140) can be ordered to cover the fingers of the 2F-85/2F-140 and therefore protect users and assets against pinch points.

You can install them using eight (8) M3 screws.

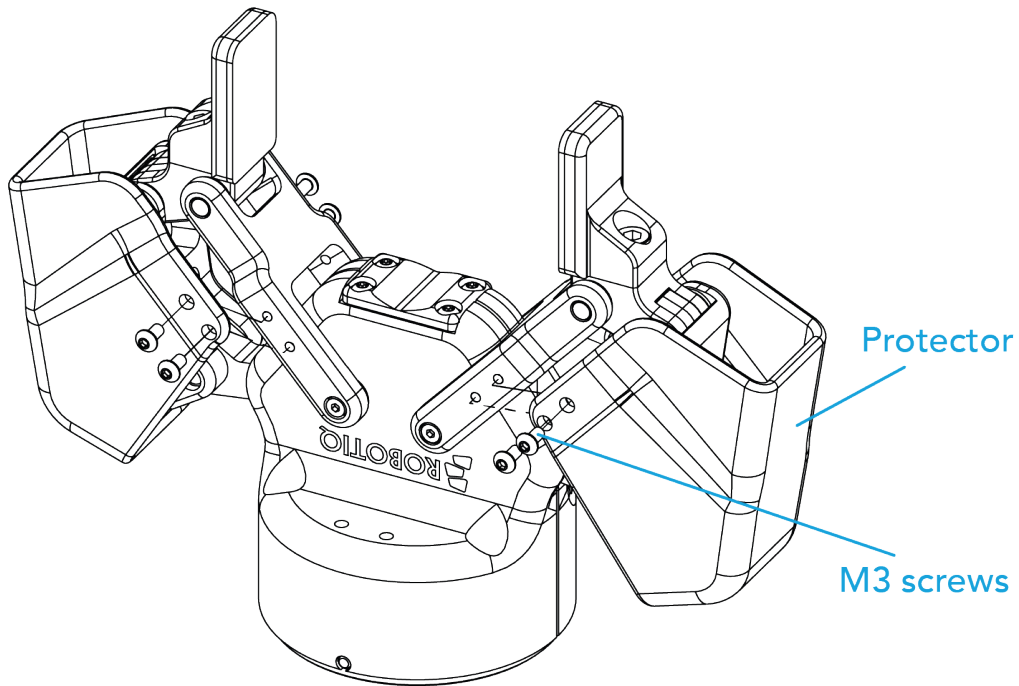

Fig. 3-5: Protector Kit Installation

3.5. Electrical Setup

Power and communication are established with the 2-Finger Adaptive Gripper via a single device cable. The device cable provides a 24V power supply to the gripper and enables serial RS485 communication to the robot controller.

Info

RS485 signals (485+, 485- and 485 GND) are isolated from the main 24V power supply. GND can be connected to any other ground reference as long as the voltage potential between the grounds does not exceed 250V. Grounding reference is at the user's discretion.

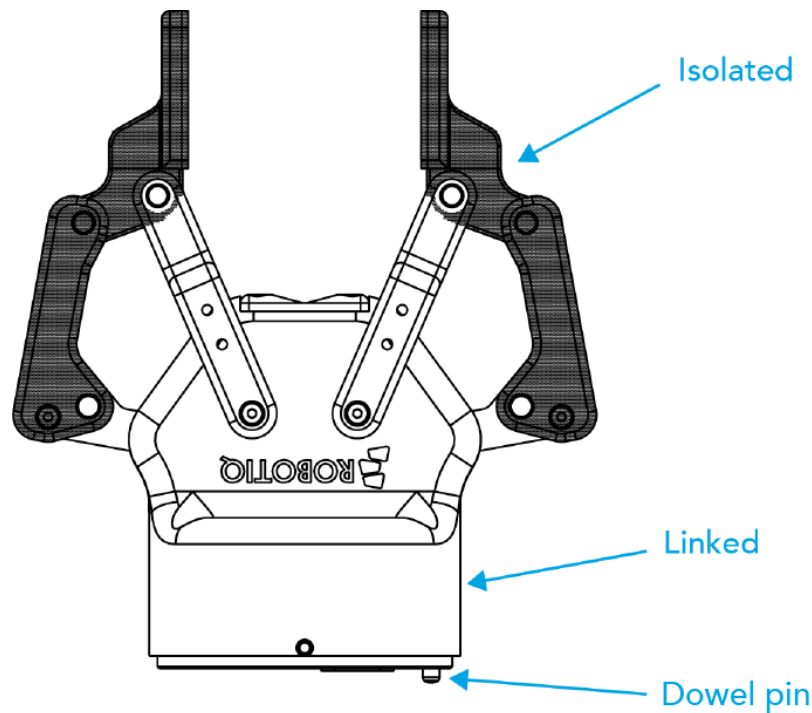

Fig. 3-6: Robotiq 2-Finger electrical isolation / grounding.

3.5.1. Electrostatic Discharge Safety

Robotiq 2F-85 & 2F-140 Gripper are not ESD safe. If installed properly using the tooth lock washers, the casing and internal mechanism are grounded through the screws used to mount the gripper on the coupling. The same is true for the coupling. For the 2F grippers, the finger mechanisms and fingertips are isolated from the rest of the gripper. It is therefore not possible to discharge any electrostatic charge that would build up on the part through the gripper.



3.5.2. Pinout Interface

The gripper interfaces with its coupling via a 10-spring pin connector located on its outer surface.

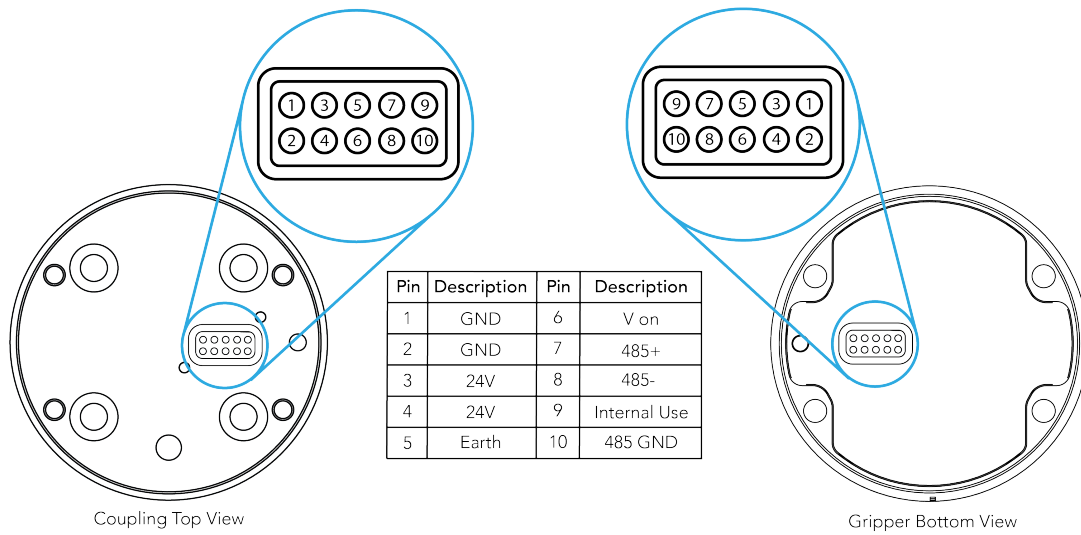

Fig. 3-7: Pinout of the 2F-85 & 2F-140 Gripper cable-to-wrist coupling

3.5.3. Coupling to Controller

Caution

Use proper cabling management. Make sure to leave enough slack in the cabling to allow movement of the gripper along all axes without pulling out the connectors. Always protect the controller-side (robot side) connector of the cable with a strain relief cable clamp.

The figure below illustrates the wiring schematic of the 2-Finger with device cable, power supply, fuse (please refer to the **Required Tools and Equipment** section), and grounding.

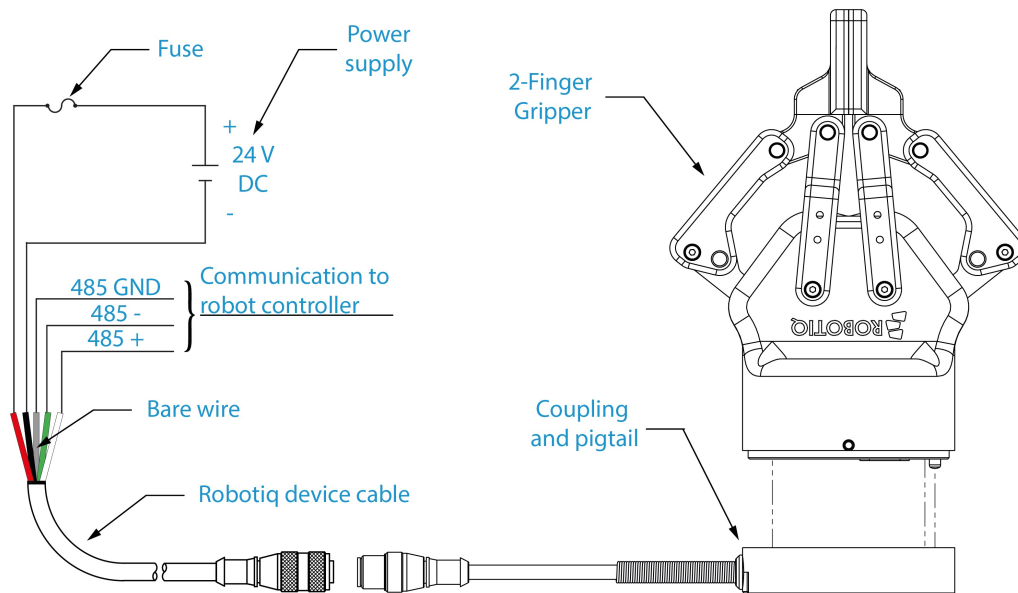

Fig. 3-8: Robotiq 2-Finger with pigtail cable and device cable wiring schematic.



The figure below illustrates the 2-Finger pigtail connector from the coupling (GRP-CPL-062 or AGC-CPL-XXX-002), the device cable on the robot side (CBL-COM-2065-XX) and their associated pinout.

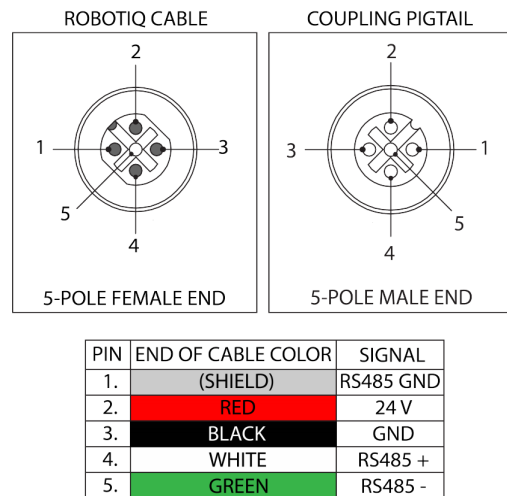

Fig. 3-9: Pinout of the 2-Finger pigtail and device cable.

If additional cable is used, suggested cable specifications are as follows:

Power supply, fusing:

- minimum #22 AWG TEW, 300 V or 600 V

RS485 signal :

- minimum #24 AWG TEW, 300 V or 600 V
- A and B signals must be balanced at 120 Ohms

Single Gripper

Prior to any software installation on Aubo robots, connect the white, green and bare wires to the Robotiq RS-485 signal converter (ACC-ADT-USB-RS485) as shown in the figure below. Also connect the red (24V) and black (0V) wires in the controller according to that same figure.

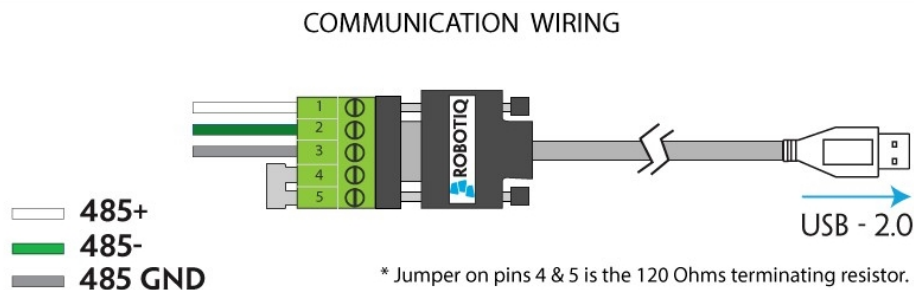

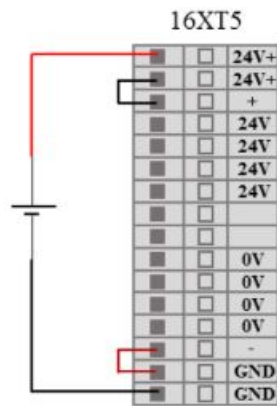

Fig. 3-10: 2-Finger Adaptive Gripper wiring to robot controller.

Multiple Grippers

It is possible to connect multiple grippers on the same robot. Only one RS485 to RS232 converter (ACC-ADT-RS232-RS485) must be used. Use M12 splitters (ACC-SPLIT-M12-2:1) to connect all the grippers pigtails to one 10m cable (CBL-COM-2065-10-HF) that connects to the RS485 to RS232 converter.

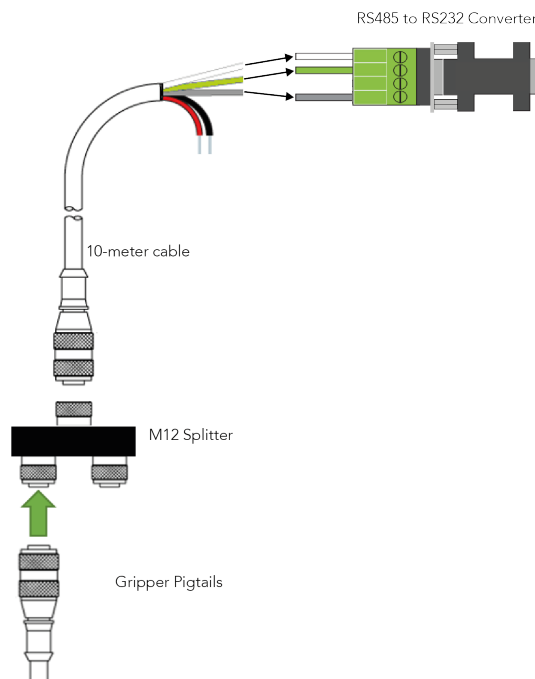

Fig. 3-11: Multiple grippers wiring

Warning

In order to connect two or more grippers at the same time on a robot, each gripper must have a coupling for the transmission of power and communication signals, a dual gripper adapter plate to mechanically mount the gripper on the robot arm, and a splitter.

Please refer to the **Spare Parts, Kits and Accessories** section for more details.



3.6. Testing the Gripper with the Robotiq User Interface (RUI)

Once installed and properly secured, your Robotiq 2-Finger Adaptive Gripper should be tested with the Robotiq User Interface test software using the provided USB converter. Follow these instructions:

- 1 Install the Robotiq User Interface (RUI). For details, see the Robotiq User Interface manual, available at robotiq.com/support.
- 2 Power up your gripper with the previously recommended power supply.
- 3 Execute the RUI software and select "auto-connect" on the connection screen.
- 4 You are now connected to your gripper, you can click "activate" to begin using the gripper.

Caution

The Activate command will initiate movement of the gripper for auto-calibration procedures. Do not interfere with the gripper. Be sure you have satisfied robot safety measures.

Tip

With the RUI controlling the gripper, you can go to the **view** menu to see input and output register values to further your understanding on how to command the gripper. You can also test grasping objects with various speed and force settings. See the **Control** section for details.



4. Control

Info

Unless specified, all values in this section are hexadecimal values.

4.1. Overview

The Robotiq 2-Finger Adaptive Gripper is controlled directly via Modbus RTU using a RS 485 signal. It can also be controlled via an optional Robotiq Universal Controller using an industrial protocol. The programming of the gripper can be done with the teach pendant of the robot or by offline programming. Communication method used to control the 2-Finger Gripper does not change the control logic or the registers setup described in the following subsections.

Tip

To test various gripper features such as object detection and force control, use the Robotiq User Interface. To download it, go to support.robotiq.com, click on **Select product > 2F-85 and 2F-140 Grippers > [any robot brand] > Software > Robotiq User Interface > DOWNLOAD ZIP**.

Since the Robotiq 2-Finger has its own embedded controller, you can use high-level commands, such as "Go to requested position" to control it.

Info

The operator can control force, speed and position of the gripper fingers.

- Finger movement is always synchronized.
- Finger movement is initiated via a single "Go to requested position" command.
- Parallel or encompassing grip is performed automatically.
- Object detection is built-in. Operator is notified after an object is picked once the "Go to" command has been initiated. The feature also works for lost or dropped objects, and the user can be alerted if an object is dropped after being detected.
- In case of emergency, auto-release is engaged (open or close).

Control using registers

Grippers share their internal memory with the robot controller. One part of the memory is for the robot output; **gripper functionalities**. The other part of the memory is for the robot input; **gripper status**. Two types of actions are then available to a robot controller:

1. Write in the **robot output** registers to activate **functionalities**;
2. Read in the **robot input** registers to get the **status** of the gripper.

The **Gripper Register Mapping** section maps the registers used to control the gripper or to read its status while the **Robot Output Registers & Functionalities** section details the output (write) register functions, and the **Robot Input Registers & Status** section details the input (read) register status. The figure below is a representation of the memory and the control logic of the gripper. For details, see the **Control Logic Example** section.



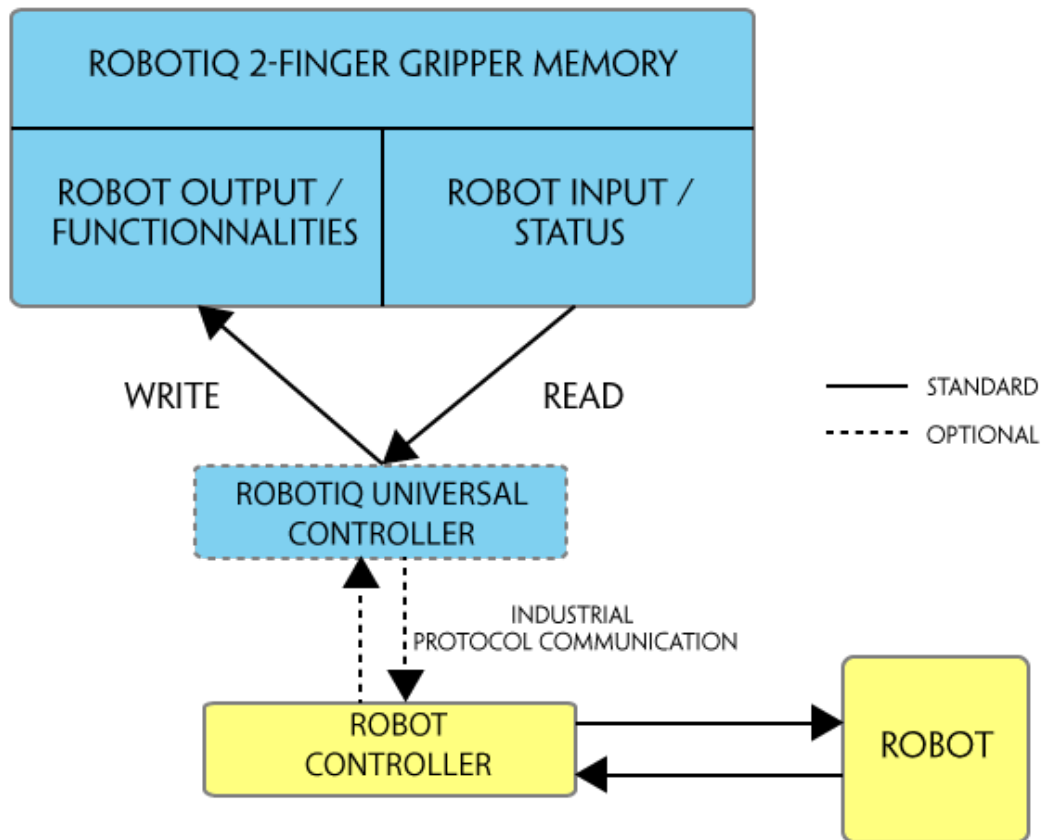

Fig. 4-1: 2-Finger control logic overview

4.2. Gripper Register Mapping

Caution

Byte numeration starts at zero and not at 1 for the functionalities and status registers.

Register	Robot Output / Functionalities	Robot Input / Status
Byte 0	ACTION REQUEST	GRIPPER STATUS
Byte 1	RESERVED	RESERVED
Byte 2	RESERVED	FAULT STATUS
Byte 3	POSITION REQUEST	POS REQUEST ECHO
Byte 4	SPEED	POSITION
Byte 5	FORCE	CURRENT
Byte 6 to 15	RESERVED	RESERVED

Table 4-1: Registers of the 2-Finger Gripper.



4.3. Robot Output Registers & Functionalities

4.3.1. Register: ACTION REQUEST

Address: Byte 0

Bits	7	6	5	4	3	2	1	0
Symbols	Reserved		rARD	rATR	rGTO	Reserved		rACT

rACT

First action to be made prior to any other actions, **rACT** bit will activate the gripper. Clear the **rACT** bit to reset the gripper and clear any fault status.

- 0x0 - Deactivate Gripper.
- 0x1 - Activate Gripper (must stay on after activation routine is completed).

Warning

When setting **rACT** ($rACT == 1$), the gripper will begin movement to complete its activation feature.

Info

Power loss will set **rACT** ($rACT == 1$); the **rACT** bit must then be cleared ($rACT == 0$), then set again to allow operation of the gripper.

Caution

The **rACT** bit must stay on afterwards for any other action to be performed.

rGTO

The "Go To" action moves the gripper fingers to the requested position using the configuration defined by the other registers, **rGTO** will engage motion while byte 3, 4 and 5 will determine aimed position, force and speed. The only motions performed without the **rGTO** bit are activation and automatic release routines.

- 0x0 - Stop.
- 0x1 - Go to requested position.



rATR

Automatic Release routine action slowly opens the gripper fingers until all motion axes reach their mechanical limits. After all motions are completed, the gripper sends a fault signal and needs to be reinitialized before any other motion is performed. The **rATR** bit overrides all other commands excluding the activation bit (**rACT**).

- 0x0 - Normal.
- 0x1 - Emergency auto-release.

Caution

The automatic release is meant to disengage the gripper after an emergency stop of the robot.

The automatic release is not intended to be used under normal operating conditions.

Automatic release will require the **rACT** to be cleared (**rACT** == 0) then set (**rACT** == 1).

rARD

Auto-release direction. When auto-releasing, **rARD** commands the direction of the movement. The **rARD** bit should be set prior to or at the same time as the **rATR** bit, as the motion direction is set when the auto-release is initiated.

- 0x0 - Closing auto-release
- 0x1 - Opening auto-release

4.3.2. Register: GRIPPER OPTIONS

Address: Byte 1

Bits	7	6	5	4	3	2	1	0
Symbol	Reserved							

4.3.3. Register: GRIPPER OPTIONS 2

Address: Byte 2

Bits	7	6	5	4	3	2	1	0
Symbol	Reserved							



4.3.4. Register: POSITION REQUEST

Address: **Byte 3**

Bits	7	6	5	4	3	2	1	0
Symbol	rPR							

This register is used to set the target position for the gripper's fingers. The positions 0x00 and 0xFF correspond respectively to the fully opened and fully closed mechanical stops. For detailed finger trajectory, please refer to the **Specifications** section.

- 0x00 - Open position, with 85 mm or 140 mm opening respectively
- 0xFF - Closed
- Opening / count: 0.4 mm (for 85 mm stroke) and 0.65 mm (for 140 mm stroke)

Info

The activation will allow the gripper to adjust to any fingertips. No matter what is the size and/or shape of the fingertips, 0 will always be fully opened and 255 fully closed, with a quasi-linear relationship between the two values.

4.3.5. Register: SPEED

Address: **Byte 4**

Bits	7	6	5	4	3	2	1	0
Symbol	rSP							

This register is used to set the gripper closing or opening speed in real time, however, **setting a speed will not initiate a motion.**

- 0x00 - Minimum speed
- 0xFF - Maximum speed



4.3.6. Register: FORCE

Address: **Byte 5**

Bits	7	6	5	4	3	2	1	0
Symbol	rFR							

The force setting defines the final gripping force for the gripper. The force will fix the maximum current sent to the motor. If the current limit is exceeded, the fingers stop and trigger an object detection notification. Please refer to the **Picking Features** section for details on force control.

- 0x00 - Minimum force
- 0xFF - Maximum force

Info

Register bytes 6 to 15 are reserved and should be set to 0.



4.4. Robot Input Registers & Status

4.4.1. Register: GRIPPER STATUS

Address: Byte 0

Bits	7	6	5	4	3	2	1	0
Symbols	gOBJ		gSTA		gGTO	Reserved		gACT

gACT

Activation status, echo of the **rACT** bit (activation bit).

- 0x0 - Gripper reset.
- 0x1 - Gripper activation.

gGTO

Action status, echo of the **rGTO** bit (**go to** bit).

- 0x0 - Stopped (or performing activation / automatic release).
- 0x1 - Go to Position Request.

gSTA

Gripper status, returns the current status and motion of the gripper fingers.

- 0x00 - Gripper is in reset (or automatic release) state. See Fault Status if gripper is activated.
- 0x01 - Activation in progress.
- 0x02 - Not used.
- 0x03 - Activation is completed.



gOBJ

Object detection status, is a built-in feature that provides information on possible object pick-up. Ignore if `gGTO == 0`.

- 0x00 - Fingers are in motion towards requested position. No object detected.
- 0x01 - Fingers have stopped due to a contact while opening before requested position. Object detected opening.
- 0x02 - Fingers have stopped due to a contact while closing before requested position. Object detected closing.
- 0x03 - Fingers are at requested position. No object detected or object has been loss / dropped.

Caution

In some circumstances the object detection feature may not detect an object even if it is successfully grasped. For instance, picking up a thin object may be successful without the object detection status being triggered. In such applications, the "Fingers are at requested position" status of register gOBJ, is sufficient to proceed to the next step of the routine.

4.4.2. Register: RESERVED

Address: Byte 1

Bits	7	6	5	4	3	2	1	0
Symbol	Reserved							

4.4.3. Register: FAULT STATUS

Address: Byte 2

Bits	7	6	5	4	3	2	1	0
Symbols	kFLT				gFLT			

gFLT

Fault status returns general error messages that are useful for troubleshooting. Fault LED (red) is present on the gripper chassis, LED can be blue, red or both and be solid or blinking.

- 0x00 - No fault (solid blue LED)
- Priority faults (solid blue LED)
 - 0x05 - Action delayed, the activation (re-activation) must be completed prior to performing the action.
 - 0x07 - The activation bit must be set prior to performing the action.

Minor faults (solid red LED)

- 0x08 - Maximum operating temperature exceeded (≥ 85 °C internally), let cool down (below 80 °C).
- 0x09 No communication during at least 1 second.



Major faults (LED blinking red/blue) - Reset is required (rising edge on activation bit (**rACT**) needed).

- 0x0A - Under minimum operating voltage.
- 0x0B - Automatic release in progress.
- 0x0C - Internal fault; contact support@robotiq.com.
- 0x0D - Activation fault, verify that no interference or other error occurred.
- 0x0E - Overcurrent triggered.
- 0x0F - Automatic release completed.

Info

While booting, status LED will be solid blue / red.

KFLT

See your optional controller manual (input registers and status).



4.4.4. Register: POSITION REQUEST ECHO

Address: **Byte 3**

Bits	7	6	5	4	3	2	1	0
Symbol	gPR							

gPR

Echo of the requested position for the gripper, value between 0x00 and 0xFF.

- 0x00 - Full opening.
- 0xFF - Full closing.

4.4.5. Register: POSITION

Address: **Byte 4**

Bits	7	6	5	4	3	2	1	0
Symbol	gPO							

gPO

Actual position of the gripper obtained via the encoders, value between 0x00 and 0xFF.

- 0x00 - Fully opened.
- 0xFF - Fully closed.

4.4.6. Register: CURRENT

Address: **Byte 5**

Bits	7	6	5	4	3	2	1	0
Symbol	gCU							

gCU

The current is read instantaneously from the motor drive, value between 0x00 and 0xFF, approximate current equivalent is 10 * value read in mA.

Tip

Built-in features like object detection and force control use the fingers' electrical current readings. The user does not need to create these features.



4.5. Picking Features

As stated in previous sections, object picking is done via a simple "Go To" command, **rGTO** bit calls for movement, while **rPR** byte is the aimed position, **rSP** and **rFR** will be the desired speed and force settings respectively. This section describes key features in object picking applications:

- Force control
- Re-grasp
- Object detection
- Object contact loss

4.5.1. Force Control

The gripping force is controlled via the **rFR** byte (refer to the **Robot Output Registers & Functionalities** section). The gripper behavior will change according to the **rFR** force requested.

- **rFR = 0** : Very fragile objects
 - Lowest force
 - Re-grasp feature is off
- **1 rFR 255** : Fragile to robust object
 - Re-grasp feature is on

Object type	Solid Fragile	Deformable Fragile	Solid Robust
rFR value	0	1	255
Force Level	Low Force		High Force
Re-grasp	OFF	ON	

The table below shows the expected applied force according to the payload material hardness, speed setting **rSP** and force setting **rFR**. All tests were done with the 2-Finger Gripper with firmware GC3-1.3.9. Data was obtained with a Load Cell from *Phidget, S Type, model 3138*.



FINGERTIP		PAYLOAD		MEASURED FORCE MIN / MAX (N)	
TYPE	HARDNESS	TYPE	HARDNESS	2-Finger 85	2-Finger 140
Steel 4340	220 HV	Steel 4340	220 HV ³	25 - 220	15 - 120
Aluminium 60611	95 HV	Aluminium 6061	95 HV	25 - 220	15 - 120
Aluminium 60611	95 HV	Silicone (TIP-204) ²	60 A Durometer	25 - 220	15 - 120
Aluminium 60611	95 HV	Silicone rubber	40 A Durometer ⁴	25 - 155	15 - 100
Aluminium 60611	95 HV	Neoprene rubber	10 A Durometer	25 - 115	15 - 75
Aluminium 60611	95 HV	Polyurethane rubber	30 OO Durometer	25 - 115	15 - 75

¹ Available with V-Groove fingertip AGC-TIP-205-0085 / AGC-TIP-421-140.

² Available with flat silicone fingertip AGC-TIP-204-085 / AGC-TIP-420-140.

³ HV refers to Vickers hardness test.

⁴ Durometer refers to Shore durometer hardness, scale A or scale OO.



MEASURED GRIP FORCE ACCORDING TO SPEED & FORCE SETTING
FOR 220 HV HARDNESS MATERIAL (STEEL)

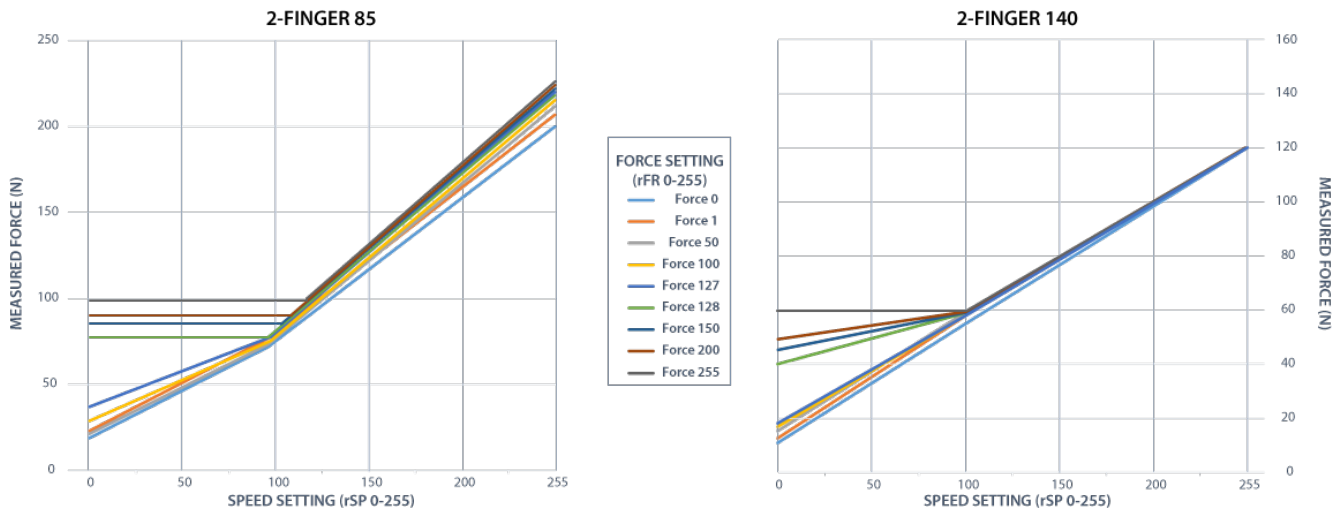

Fig. 4-2: Grip force on hardness 220 HV (4340 annealed carbon steel).

MEASURED GRIP FORCE ACCORDING TO SPEED & FORCE SETTING
FOR 95 HV HARDNESS MATERIAL (ALUMINIUM)

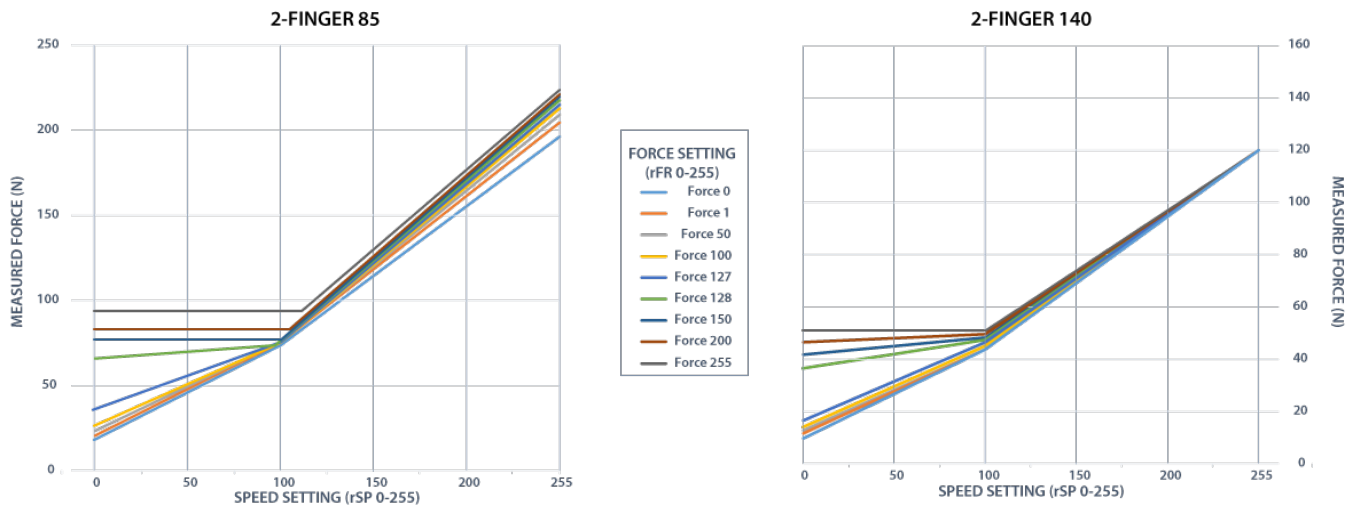

Fig. 4-3: Grip force on hardness 95 HV (6061-T6 aluminium).



MEASURED GRIP FORCE ACCORDING TO SPEED & FORCE SETTING FOR 60A DUROMETER MATERIAL

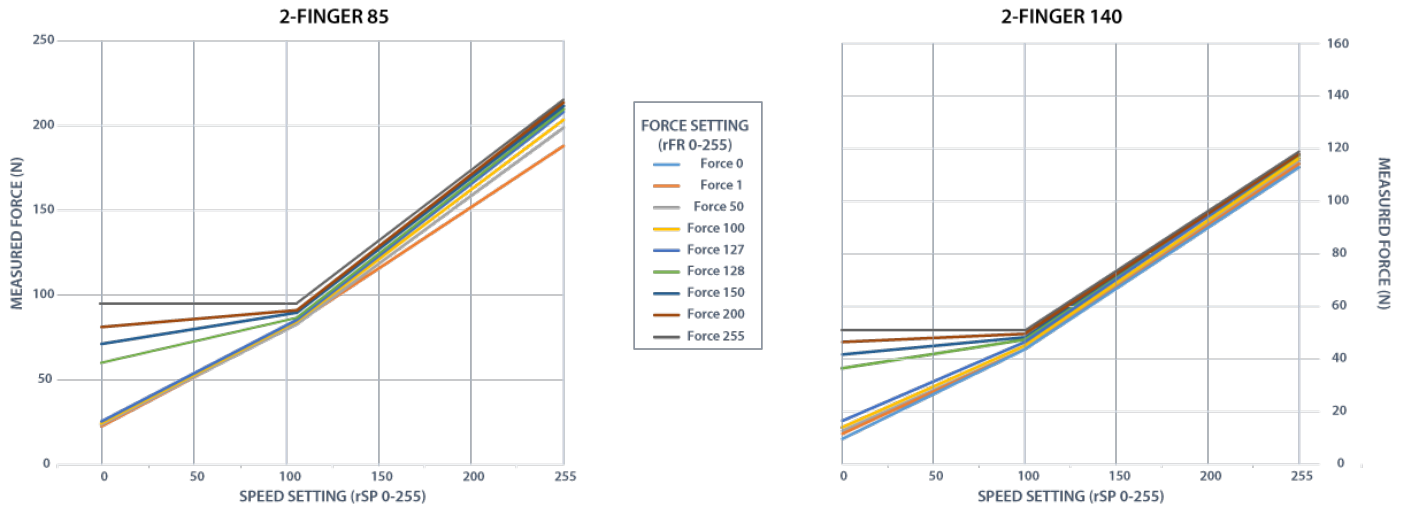

Fig. 4-4: Grip force on hardness 60A (silicone).

MEASURED GRIP FORCE ACCORDING TO SPEED & FORCE SETTING FOR 40A DUROMETER MATERIAL

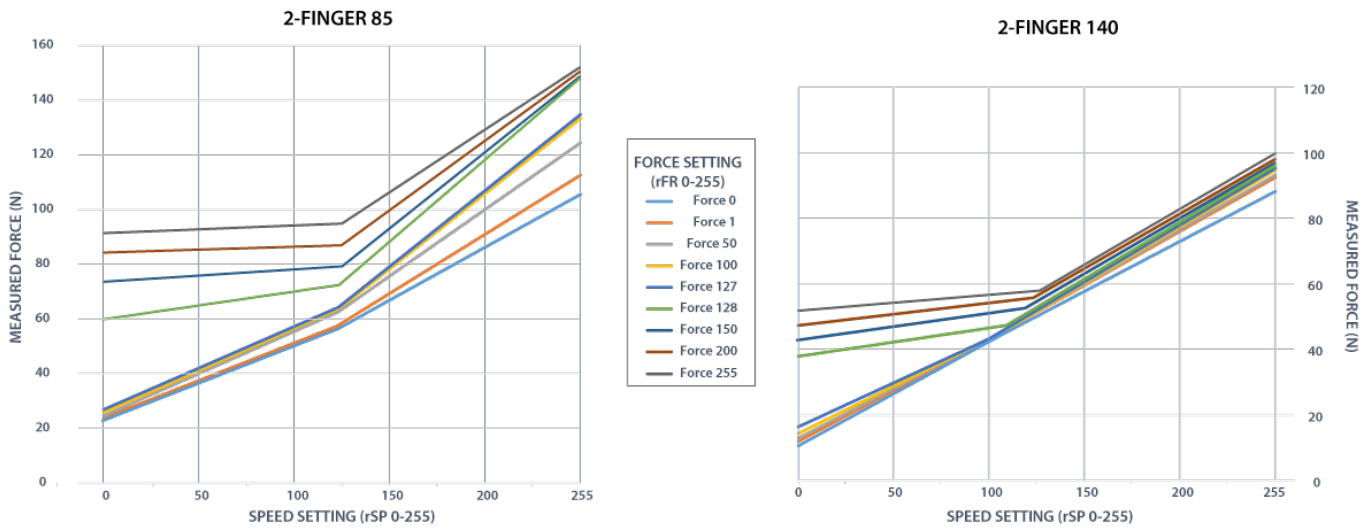

Fig. 4-5: Grip force on hardness 40 A (silicone).



MEASURED GRIP FORCE ACCORDING TO SPEED & FORCE SETTING FOR 10A DUROMETER MATERIAL

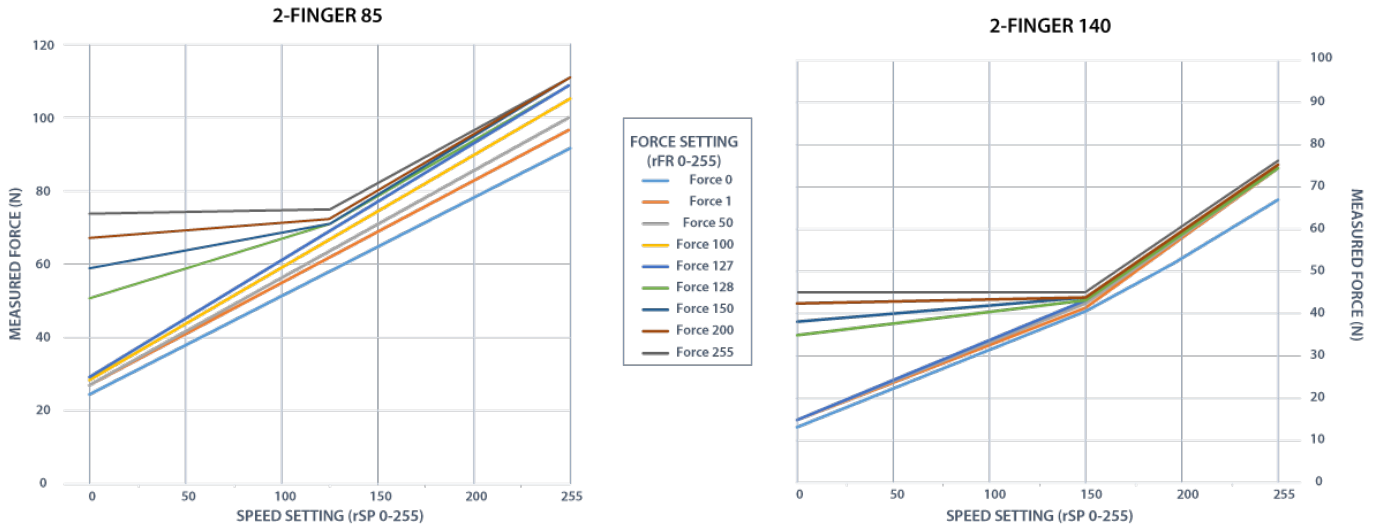

Fig. 4-6: Grip force on hardness 10 A (neoprene).

MEASURED GRIP FORCE ACCORDING TO SPEED & FORCE SETTING FOR 3000 DUROMETER MATERIAL

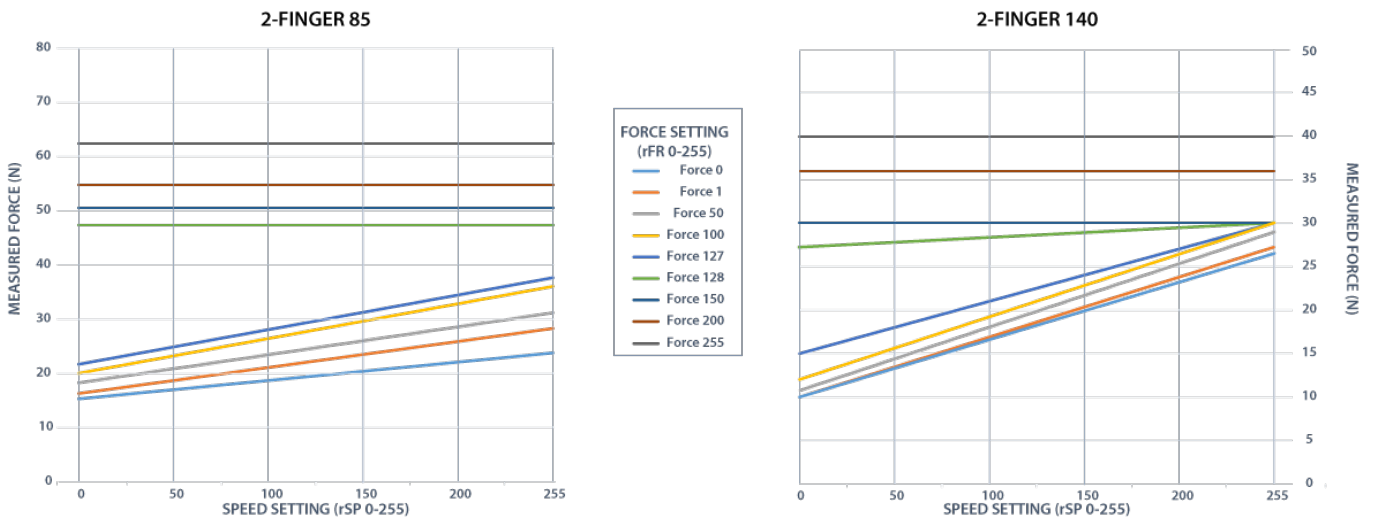

Fig. 4-7: Grip force on hardness 30 OO (polyurethane).



4.5.2. Re-Grasp

Re-grasp feature is a built-in feature meant to prevent object lost due to slipping or inaccurate initial grip. The Re-grasp feature allows the gripper to initiate movement when an object is slipping or dropped. When Re-grasping, the gripper will attempt to close until it reaches the position request (**rPR**).

- This feature is automatically set according to the force request **rFR**.

Info

Feature is off at force request $rFR = 0$, otherwise it is on.

- Re-grasp will keep the position setting:
 - Finger motion will stop when **rPR** position is reached, even if there is no object.
- Force and speed settings are not used, Re-grasp force and speed will automatically adjust to keep the object from being lost / dropped.

Info

While your initial settings for force and speed are not used for Re-grasp, they will never be exceeded to prevent damaging the object.

Caution

The rOBJ status is cleared when a finger motion is detected.



4.5.3. Object detection

When the gripper grabs an object, **gOBJ** status will allow you to know if contact with the object was successful. This is a built-in feature for adaptive grippers meant to be used by the robot controller (or PLC) commanding the overall application. The Object detection feature will change the **gOBJ** status and can be used inside your robot program.

As stated in the previous section:

gOBJ: Only valid if **gGTO** = 1.

- 0x00 - Fingers are in motion towards requested position. No object detected.
- 0x01 - Fingers have stopped due to a contact while opening before requested position. Object detected.
- 0x02 - Fingers have stopped due to a contact while closing before requested position. Object detected.
- 0x03 - Fingers are at requested position. No object detected or object has been lost / dropped.

Example of contact detected with an object:

1. Set position, speed and force at maximum (full closing):
 - a. **rPR** == 0xFF, **rSP** == 0xFF, **rFR** == 0xFF,
2. Set "go to requested" will initiate movement :
 - a. **rGTO** == 0x01
3. Then object detection status will be "in motion"
 - a. **gOBJ** = 0x00
4. Until an object is picked, object detection status will then be "stopped due to contact while closing"
 - a. **gOBJ** = 0x02
5. The user can now assume it is holding the payload, and proceed to the next step.

Example of contact lost with an object:

1. From previous example, after an object is picked
 - a. **gOBJ** = 0x02
2. If the **gOBJ** status displays 0x03 after it was 0x02, user can assume contact with the object has been lost.



4.6. Control Logic Example

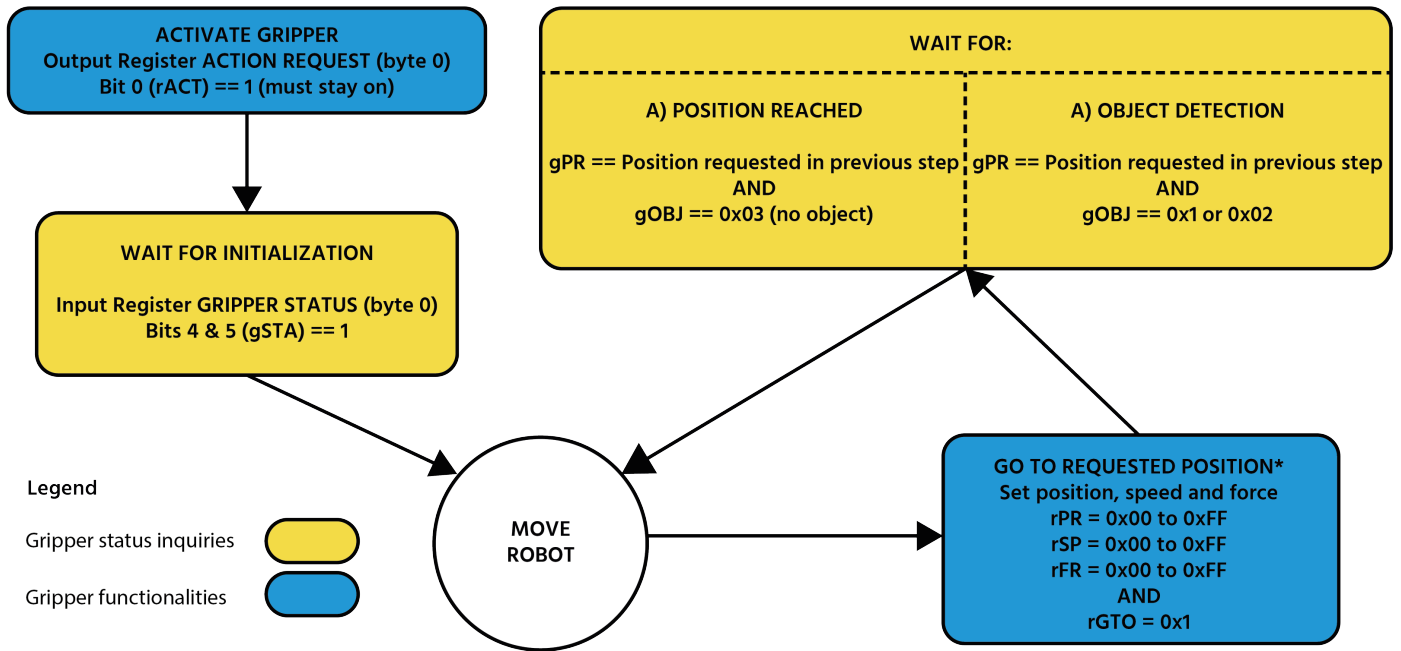

Go to requested position is used to open/close the Gripper until a contact with the object is detected, or the requested position is reached.

Fig. 4-8: Example of Gripper control logic with corresponding registers.



4.7. Modbus RTU Communication

The gripper can be controlled by Modbus RTU directly with RS485-RS232 using the ACC-ADT-RS232-RS485, or over USB using the ACC-ADT-USB-RS485. This section is intended to provide guidelines for setting up a Modbus master that will adequately communicate with the gripper.

For a general introduction to Modbus RTU and for details regarding the CRC algorithm, the reader is invited to read the Modbus over serial line specification and implementation guide available at: http://www.modbus.org/docs/Modbus_over_serial_line_V1_02.pdf.

For debugging purposes, the reader is also invited to download one of many free Modbus scanners such as the *CAS Modbus Scanner* from Chipkin Automation Systems available at: <http://www.store.chipkin.com/products/tools/cas-modbus-scanner>.

Info

Modbus RTU is a communication protocol based on a Big Endian byte order. Therefore, the 16-bit register addresses are transmitted with the most significant byte first. However, the data port is in the case of Robotiq products based on the Little Endian byte order. As such, the data parts of Modbus RTU messages are sent with the less significant byte first.

Tip

Modbus RTU specification and details can be found at www.modbus.org.



4.7.1. Connection Setup

The following table describes the connection requirements for controlling the gripper using the Modbus RTU protocol.

PROPRIETY	DEFAULT VALUE
Physical Interface	RS-485 ¹
Baud Rate ²	115,200 bps
Data Bits	8
Stop Bit ²	1
Parity ²	None
Supported Functions	Read Input Registers (FC04) Preset Multiple Register (FC16) Master read & write multiple registers (FC23)
Exception Responses	Not supported
Slave ID ²	0x0009 (9)
Robot Output / Gripper Input First Register	0x03E8 (1000)
Robot Input / Gripper Output First Register	0x07D0 (2000)
Termination Resistor ²	120 ohms

¹ Various converters are available in the **Spare Parts, Kits and Accessories** section.

² These parameters can be adjusted using the Robotiq User Interface.

Each register (word - 16 bits) of the Modbus RTU protocol is composed of **2** bytes (8 bits) from the gripper. The first gripper output Modbus register(0x07D0) is composed from the first **2** Robotiq Gripper bytes (byte 0 and byte 1).

Info

200 Hz is the maximum speed when commanding / reading from the Robotiq Gripper. It is therefore recommended to send commands with a minimum delay of 5 ms between them.

Info

Maximum baud rate of **ACC-ADT-USB-RS485** is 115200 bps.

120 Ohms termination resistor is already present on the converter and the gripper. If multiple grippers are connected in parallel on the same RS485 cable, termination resistor must be set to OFF in communication parameters.



4.7.2. Read input registers (FC04)

Function code 04 (FC04) is used for requesting the status of the gripper analog input register. Examples of such data are gripper status, object status, finger position, etc.

Example of an FC04 read function:

This message asks for register 0x07D0 (2000) and register 0x07D1 (2001) which contains Gripper Status, Object Detection, Fault Status and Position Request Echo.

Request is: 09 04 07 D0 00 02 70 0E

Bits	Description
09	SlaveID
04	Function Code 04 (Read Input Registers)
07D0	Address of the first requested register
0002	Number of registers requested (2)
700E	Cyclic Redundancy Check (CRC)

Response is: 09 04 04 E0 00 00 00 45 84

Bits	Description
09	SlaveID
04	Function Code 04 (Read Input Registers)
04	Number of data bytes to follow (2 registers x 2 bytes/register = 4 bytes)
E000	Content of register 07D0
0000	Content of register 07D1
4584	Cyclic Redundancy Check (CRC)



4.7.3. Preset multiple registers (FC16)

Function code 16 (FC16) is used to activate functionalities of the gripper (robot output). Examples of such data are action request, speed, force, etc.

Example of setting multiple registers FC16:

This message requests to set position request, speed and force of the gripper by setting register 0x03E9 (1002) and 0x03EA.

Request is: 09 10 03 E9 00 02 04 60 E6 3C C8 EC 7C

Bits	Description
09	SlaveID
10	Function Code 16 (Preset Multiple Registers)
03E9	Address of the first register
0002	Number of registers written to
04	Number of data bytes to follow (2 registers x 2 bytes/register = 4 bytes)
60E6	Value written to register 0x03E9
3CC8	Value written to register 0x03EA
EC7C	Cyclic Redundancy Check (CRC)

Response is: 09 10 03 E9 00 02 91 30

Bits	Description
09	SlaveID
10	Function Code 16 (Preset Multiple Registers)
03E9	Address of the first register
0002	Number of written registers
9130	Cyclic Redundancy Check (CRC)



4.7.4. Master read & write multiple registers FC23

Function code 23 (FC23) is used for reading the status of the gripper (robot input) and activating gripper functionalities (robot output) simultaneously. Examples of such data are Gripper status, object status, finger position, etc. Action requests are speed, force, etc.

Example of reading and writing multiple registers FC23:

This message reads registers 0x07D0 (2000) and 0x07D1 (2001), which contains Gripper Status, Object Detection, Fault Status and Position Request Echo. It also sets the position request, speed and force of the gripper by writing to registers 0x03E9 (1001) and 0x03EA (1002).

Request is: 09 17 07 D0 00 02 03 E9 00 02 04 00 E6 3C C8 2D 0C

Bits	Description
09	SlaveID
17	Function Code 23 (read and write multiple registers)
07D0	Address of the first requested register, read
0002	Number of registers requested (2), read
03E9	Address of the first register written to
0002	Number of registers written to (2)
04	Number of data bytes to follow (2 registers X 2 bytes/registers = 4 bytes)
00E6	Value written to register 0x03E9
3CC8	Value written to register 0x03EA
2D0C	Cyclic Redundancy Check (CRC)



Response is: 09 17 04 01 00 09 E6 F6 C1

Bits	Description
09	SlaveID
17	Function Code 23 (read and write multiple registers)
04	Number of data bytes to follow (2 registers x 2 bytes/register = 4 bytes)
1000	Content of register 07D0
09E6	Content of register 07D1
F6C1	Cyclic Redundancy Check (CRC)

Tip

Response contents might change depending on gripper status.

Info

Gripper executes the input command ("write" command), executes one cycle of motion, updates the output, then returns the Modbus response read.



4.7.5. Modbus RTU example

This section depicts the example from the **Control Logic Example** section, when programmed using the Modbus RTU protocol. The example is typical of a pick and place application. After activating the gripper, the robot is moved to a pick-up location to grip an object. It moves again to a second location to release the gripped object.

Step 1: Activation Request (clear and set rACT)

Request is (clear rAct): 09 10 03 E8 00 03 06 00 00 00 00 00 00 73 30

Bits	Description
09	SlaveID
10	Function Code 16 (Preset Multiple Registers)
03E8	Address of the first register
0003	Number of registers written to
06	Number of data bytes to follow (3 registers x 2 bytes/register = 6 bytes)
0000	Value to write to register 0x03E9 (ACTION REQUEST = 0x01 and GRIPPER OPTIONS = 0x00): rACT = 1 for "Activate Gripper"
0000	Value written to register 0x03EA
0000	Value written to register 0x03EB
7330	Cyclic Redundancy Check (CRC)

Response is: 09 10 03 E8 00 03 01 30

Bits	Description
09	SlaveID
10	Function Code 16 (Preset Multiple Registers)
03E8	Address of the first register
0003	Number of written registers
0130	Cyclic Redundancy Check (CRC)



Request is (set rAct): 09 10 03 E8 00 03 06 01 00 00 00 00 00 72 E1

Bits	Description
09	SlaveID
10	Function Code 16 (Preset Multiple Registers)
03E8	Address of the first register
0003	Number of registers written to
06	Number of data bytes to follow (3 registers x 2 bytes/register = 6 bytes)
0100	Value to write to register 0x03E9 (ACTION REQUEST = 0x01 and GRIPPER OPTIONS = 0x00): rACT = 1 for "Activate Gripper"
0000	Value written to register 0x03EA
0000	Value written to register 0x03EB
72E1	Cyclic Redundancy Check (CRC)

Response is: 09 10 03 E8 00 03 01 30

Bits	Description
09	SlaveID
10	Function Code 16 (Preset Multiple Registers)
03E8	Address of the first register
0003	Number of written registers
0130	Cyclic Redundancy Check (CRC)



Step 2: Read Gripper status until the activation is completed

Request is: 09 04 07 D0 00 01 30 0F

Bits	Description
09	SlaveID
04	Function Code 04 (Read Input Registers)
07D0	Address of the first requested register
0001	Number of registers requested (1)
300F	Cyclic Redundancy Check (CRC)

Response (if the activation IS NOT completed): 09 04 02 11 00 54 A1

Bits	Description
09	SlaveID
04	Function Code 04 (Read Input Registers)
02	Number of data bytes to follow (1 register x 2 bytes/register = 2 bytes)
1100	Content of register 07D0 (GRIPPER STATUS = 0x11, RESERVED = 0x00): gACT = 1 for "Gripper Activation", gSTA = 1 for "Activation in progress"
54A1	Cyclic Redundancy Check (CRC)

Response (if the activation IS completed): 09 04 02 31 00 4D 61

Bits	Description
09	SlaveID
04	Function Code 04 (Read Input Registers)
02	Number of data bytes to follow (1 register x 2 bytes/register = 2 bytes)
3100	Content of register 07D0 (GRIPPER STATUS = 0x31, RESERVED = 0x00): gACT = 1 for "Gripper Activation", gSTA = 3 for "Activation is completed"
4D61	Cyclic Redundancy Check (CRC)



Step 3: Move the robot to the pick-up location

Step 4: Close the Gripper at full speed and full force

Request is: 09 10 03 E8 00 03 06 09 00 00 FF FF FF 42 29

Bits	Description
09	SlaveID
10	Function Code 16 (Preset Multiple Registers)
03E8	Address of the first register
0003	Number of registers written to
06	Number of data bytes to follow (3 registers x 2 bytes/register = 6 bytes)
0900	Value written to register 0x03E8 (ACTION REQUEST = 0x09 and GRIPPER OPTIONS = 0x00): rACT = 1 for "Activate Gripper", rGTO = 1 for "Go to Requested Position"
00FF	Value written to register 0x03E9 (GRIPPER OPTIONS 2 = 0x00 and POSITION REQUEST = 0xFF): rPR = 255/255 for full closing of the Gripper
FFFF	Value written to register 0x03EA (SPEED = 0xFF and FORCE = 0xFF): full speed and full force
4229	Cyclic Redundancy Check (CRC)

Response is: 09 10 03 E8 00 03 01 30

Bits	Description
09	SlaveID
10	Function Code 16 (Preset Multiple Registers)
03E8	Address of the first register
0003	Number of written registers
0130	Cyclic Redundancy Check (CRC)



Step 5: Read Gripper status until the grasp is completed

Request is: 09 04 07 D0 00 03 B1 CE

Bits	Description
09	SlaveID
04	Function Code 04 (Read Input Registers)
07D0	Address of the first requested register
0003	Number of registers requested (3)
B1CE	Cyclic Redundancy Check (CRC)

Example of response if the grasp **is not completed**: 09 04 06 39 00 00 FF 0E 0A B6 6D

Bits	Description
09	SlaveID
04	Function Code 04 (Read Input Registers)
06	Number of data bytes to follow (3 registers x 2 bytes/register = 6 bytes)
3900	Content of register 07D0 (GRIPPER STATUS = 0x39, RESERVED = 0x00): gACT = 1 for "Gripper Activation", gGTO = 1 for "Go to Position Request" and gOBJ = 0 for "Fingers are in motion"
00FF	Content of register 07D1 (FAULT STATUS = 0x00, POSITION REQUEST ECHO = 0xFF): the position request echo tells that the command was well received and that the GRIPPER STATUS is valid.
0E0A	Content of register 07D2 (POSITION = 0x0E, FINGER CURRENT = 0x0A): the position is 14/255 and the motor current is 100mA (these values will change during motion)
B66D	Cyclic Redundancy Check (CRC)



Example of response if the grasp is completed: 09 04 06 B9 00 00 FF BD 00 5C 9A

Bits	Description
09	SlaveID
04	Function Code 04 (Read Input Registers)
06	Number of data bytes to follow (3 registers x 2 bytes/register = 6 bytes)
B900	Content of register 07D0 (GRIPPER STATUS = 0xB9, RESERVED = 0x00): gACT = 1 for "Gripper Activation", gGTO = 1 for "Go to Position Request" and gOBJ = 2 for "Fingers have stopped due to a contact while closing"
00FF	Content of register 07D1 (FAULT STATUS = 0x00, POSITION REQUEST ECHO = 0xFF): the position request echo tells that the command was well received and that the GRIPPER STATUS is valid.
BD00	Content of register 07D2 (POSITION = 0xBD, FINGER CURRENT = 0x00): the position is 189/255 (can be used to validate the size of the seized object)
5C9A	Cyclic Redundancy Check (CRC)



Step 6: Move the robot to the release location

Step 7: Open the Gripper at full speed and full force

Request is: 09 10 03 E8 00 03 06 09 00 00 00 FF FF 72 19

Bits	Description
09	SlaveID
10	Function Code 16 (Preset Multiple Registers)
03E8	Address of the first register
0003	Number of registers written to
06	Number of data bytes to follow (3 registers x 2 bytes/register = 6 bytes)
0900	Value written to register 0x03E8 (ACTION REQUEST = 0x09 and GRIPPER OPTIONS = 0x00): rACT = 1 for "Activate Gripper", rGTO = 1 for "Go to Requested Position"
0000	Value written to register 0x03E9 (GRIPPER OPTIONS 2 = 0x00 and POSITION REQUEST = 0x00): rPR = 0/255 for full opening of the Gripper (partial opening would also be possible)
FFFF	Value written to register 0x03EA (SPEED = 0xFF and FORCE = 0xFF): full speed and full force
7219	Cyclic Redundancy Check (CRC)

Response is: 09 10 03 E8 00 03 01 30

Bits	Description
09	SlaveID
10	Function Code 16 (Preset Multiple Registers)
03E8	Address of the first register
0003	Number of written registers
0130	Cyclic Redundancy Check (CRC)



Step 8: Read Gripper status until the opening is completed

Request is: 09 04 07 D0 00 03 B1 CE

Bits	Description
09	SlaveID
04	Function Code 04 (Read Input Registers)
07D0	Address of the first requested register
0003	Number of registers requested (3)
B1CE	Cyclic Redundancy Check (CRC)

Example of response if the opening is **not** completed: 09 04 06 39 00 00 00 BB 10 71 06

Bits	Description
09	SlaveID
04	Function Code 04 (Read Input Registers)
06	Number of data bytes to follow (3 registers x 2 bytes/register = 6 bytes)
3900	Content of register 07D0 (GRIPPER STATUS = 0x39, RESERVED = 0x00): gACT = 1 for "Gripper Activation", gGTO = 1 for "Go to Position Request" and gOBJ = 0 for "Fingers are in motion"
0000	Content of register 07D1 (FAULT STATUS = 0x00, POSITION REQUEST ECHO = 0x00): the position request echo tells that the command was well received and that the GRIPPER STATUS is valid.
BB10	Content of register 07D2 (POSITION = 0xBB, FINGER CURRENT = 0x10): the position is 187/255 and the motor current is 160mA (these values will change during motion)
7106	Cyclic Redundancy Check (CRC)



Example of response if the opening is **completed**: 09 04 06 F9 00 00 00 0D 00 17 AA

Bits	Description
09	SlaveID
04	Function Code 04 (Read Input Registers)
06	Number of data bytes to follow (3 registers x 2 bytes/register = 6 bytes)
F900	Content of register 07D0 (GRIPPER STATUS = 0xF9, RESERVED = 0x00): gACT = 1 for "Gripper Activation", gGTO = 1 for "Go to Position Request" and gOBJ = 3 for "Fingers are at requested position"
0000	Content of register 07D1 (FAULT STATUS = 0x00, POSITION REQUEST ECHO = 0x00): the position request echo tells that the command was well received and that the GRIPPER STATUS is valid.
0D00	Content of register 07D2 (POSITION = 0x0D, FINGER CURRENT = 0x00): the position is 13/255 (the fingers have reached their software limit)
17AA	Cyclic Redundancy Check (CRC)

Step 9: To grip additional objects, loop from step 3



4.8. Control over Aubo i5

The Gripper Plugin package contains many features to program and control the gripper. The package provides:

- Gripper node: The Gripper Plugin package adds a Gripper node that is used to add a Gripper command. A node can make the gripper move to a specific opening, grasp an object and modify the speed and force applied by the gripper.

4.8.1. Gripper Dashboard

Overview

Single Gripper

To activate the gripper:

- 1 Go to the **Extensions** tab on the top of the AUBORPE and go in the **Gripper** tab under **Peripheral** (on the left).
- 2 Enter the ID of the gripper (default for ROBOTIQ grippers is 9)
- 3 Connect to the gripper by pressing the **Connect** button
- 4 Press the **Activate Gripper** button to activate the button

To control the gripper independently:

- 1 Go to the **Control** tab (under **Extensions** tab)
- 2 It is now possible to set values for the position, speed, and force of the gripper as well as open or close it

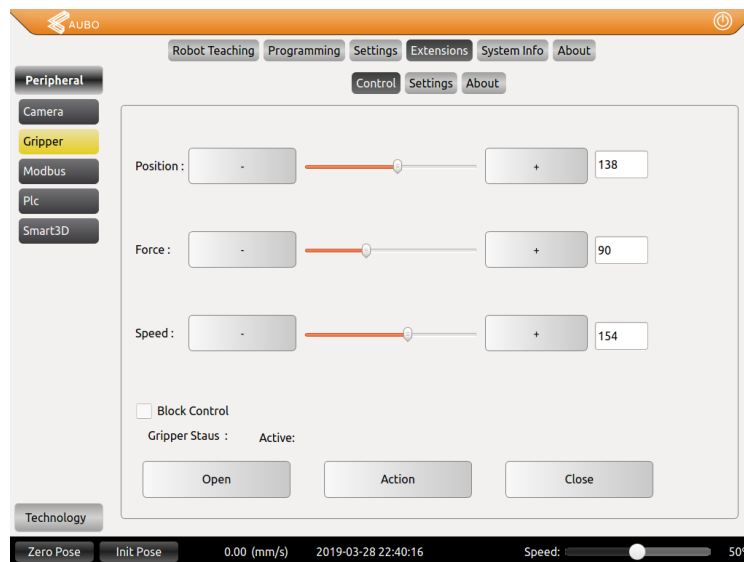

Fig. 4-9: User Interface to control the gripper independently.



Multiple Grippers

- 1 Plug one of the grippers to a computer using the USB cable
- 2 Open the Robotiq User Interface (RUI)
- 3 Connect to the gripper
- 4 In the **Modbus RTU** tab, change the gripper ID to something other than the default ID (default is 9)

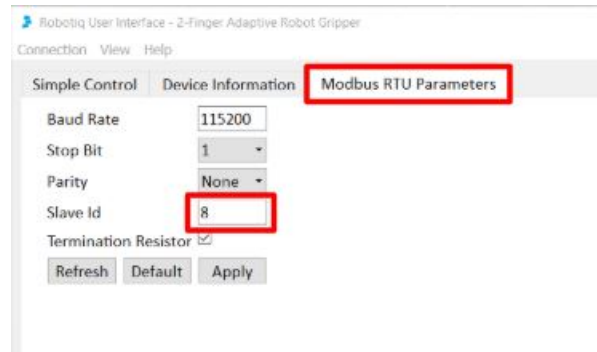

Fig. 4-10: Modification of the gripper ID

- 5 Press apply, then refresh to apply the changes
- 6 Connect both grippers to the AUBO controller using the splitter
- 7 To activate the grippers:
 - a Go in the **Extensions** tab at the top of the AUBORPE

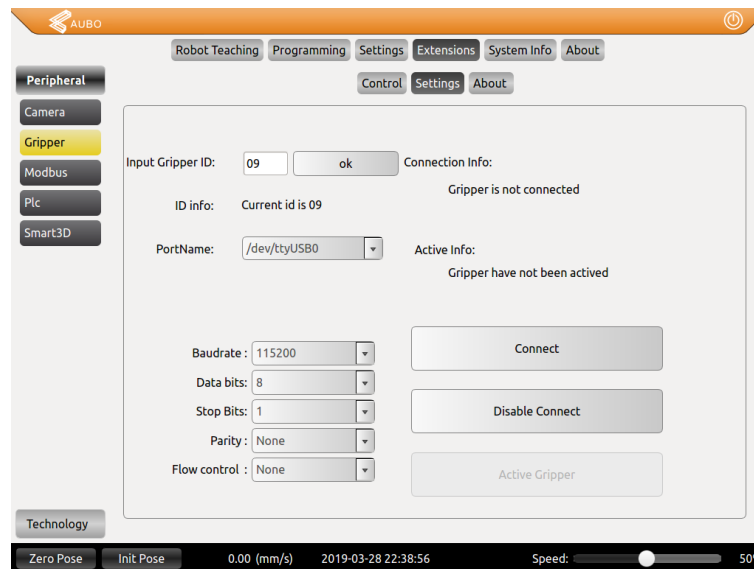

Fig. 4-11: AUBORPE user interface

- b Select the **Gripper** tab on the left and go to the **Settings** tab at the top
- c Input the first gripper's ID and press the **Connect** button
- d Press the **Activate Gripper** button
- e Once the gripper is activated, press the **Disable Connect** button to disconnect from the gripper
- f Repeat these steps with the second gripper's ID



- 8 Once the grippers are activated, they can be used in programs:
 - a When adding a Gripper node to the program, simply input the ID of the desired gripper to control it

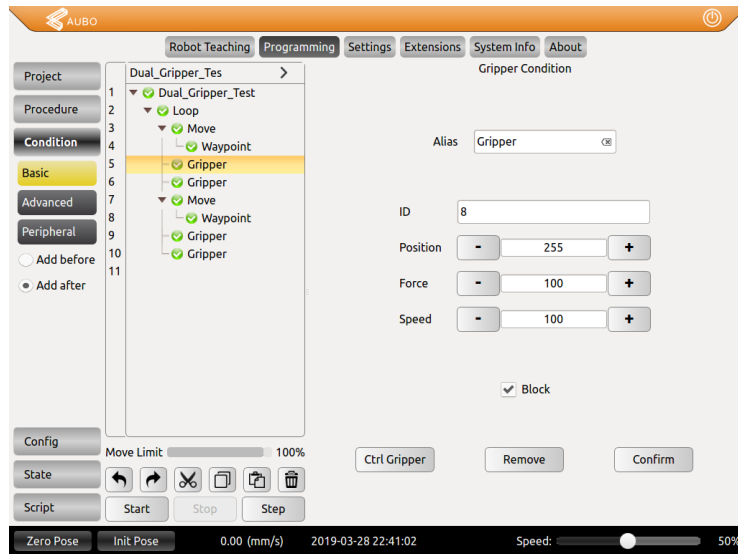

Fig. 4-12: Using the grippers in programs.

4.8.2. Programming

To control the gripper from the **Programming** tab:

- 1 To add a gripper node, go under the **Condition** tab on the left, and then press **Peripheral**
- 2 Press the **Gripper** button to add a gripper node
- 3 When adding a Gripper node to the program, simply input the ID of the desired gripper to control it (default is 9 for Robotiq products)

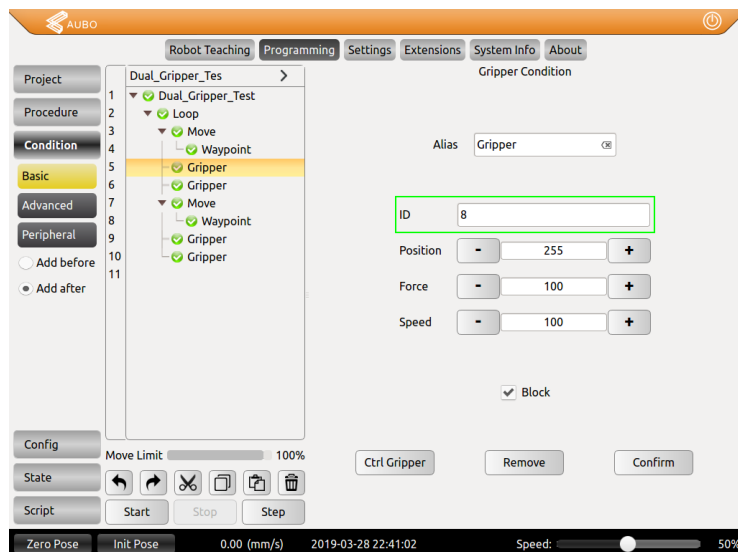

Fig. 4-13: Input the ID of the gripper.

- 4 Press the Gripper node in the programming tree to set the values of position, speed and force.



5. Specifications

Info

This manual uses the metric system. Unless otherwise specified, **all dimensions are in millimeters.**

The following subsections provide data on the various specifications for the Robotiq 2-Finger 85 and 140 Adaptive Grippers.

- **Technical dimensions** section
 - Dimensions of the Gripper
 - Dimensions of couplings
 - Dimensions for custom fingertips
 - Dimensions of standard fingertips
- **Mechanical specifications** section
- **Electrical specifications** section



5.1. Technical dimensions

5.1.1. 2-Finger 85 and 2-Finger 140 Gripper

The 2-Finger 85 and 2-Finger 140 share the same basic chassis and thus have the same technical dimensions for everything except the fingers. The figure below represents the Robotiq 2-Finger 85 Adaptive Gripper's dimensions with axis X, Y, Z and origin referenced for finger motion. Fig. 5-3 shows the equivalent with 140 mm fingers (2-Finger 140).

Info

All technical drawings in the present section are shown with NBR overmolded fingertip option: **AGC-TIP-MLD-85** (2-Finger 85) or **AGC-TIP-MLD-140** (2-Finger 140).

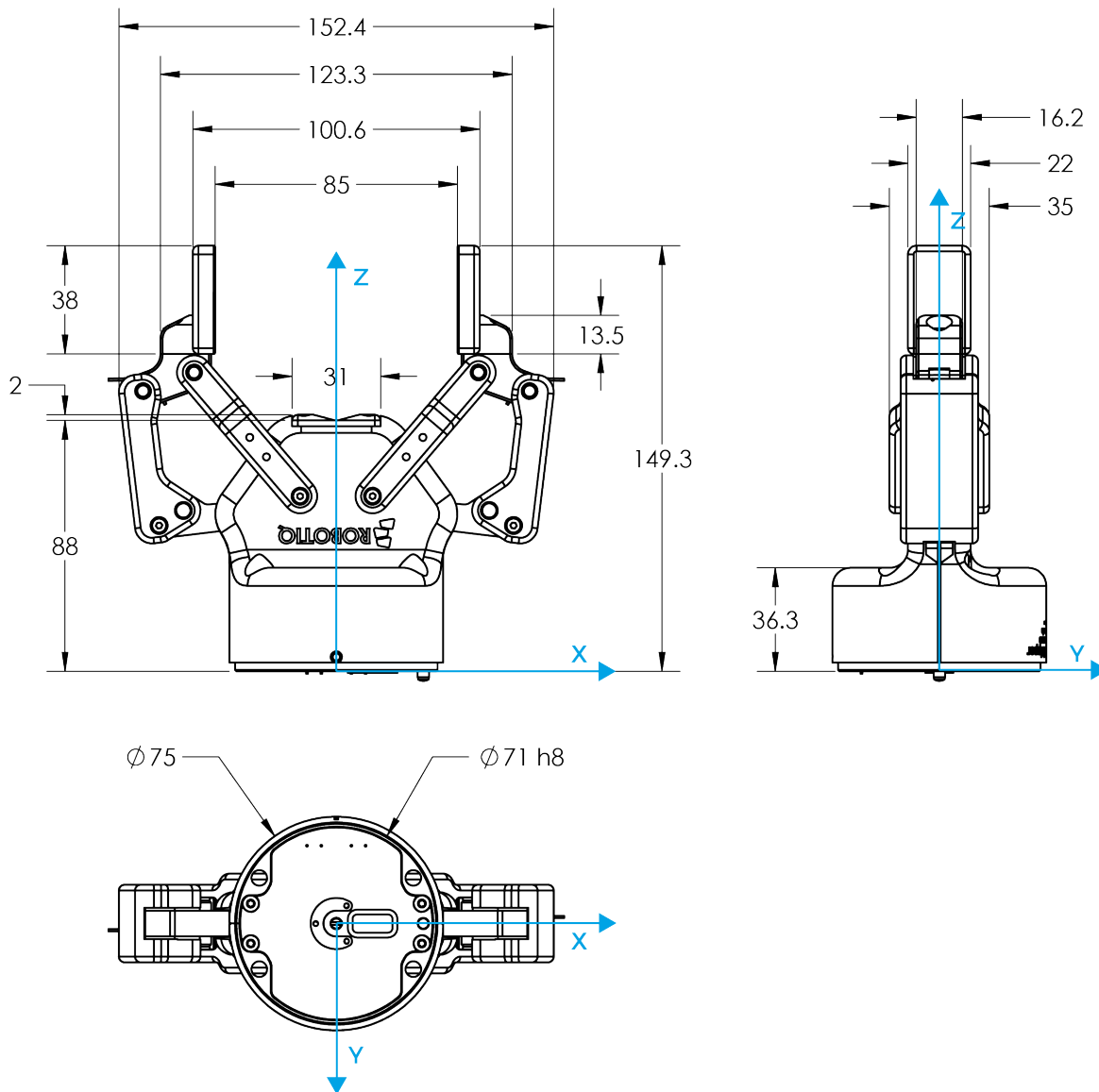

Fig. 5-1: General dimensions of 2F-85 (opened).

The height and width of the fingers vary with opening position. The figure above represents the 2F-85 Gripper in the opened position (position request = 0), while the figure below represents the 2F-85 Gripper in the closed position (position request = 255).



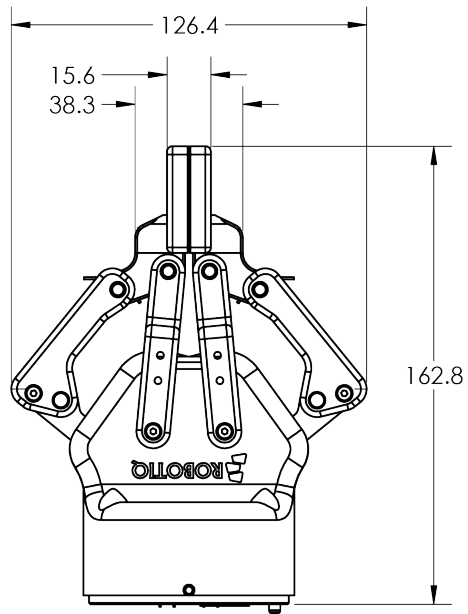

Fig. 5-2: 2F-85 dimensions (closed).

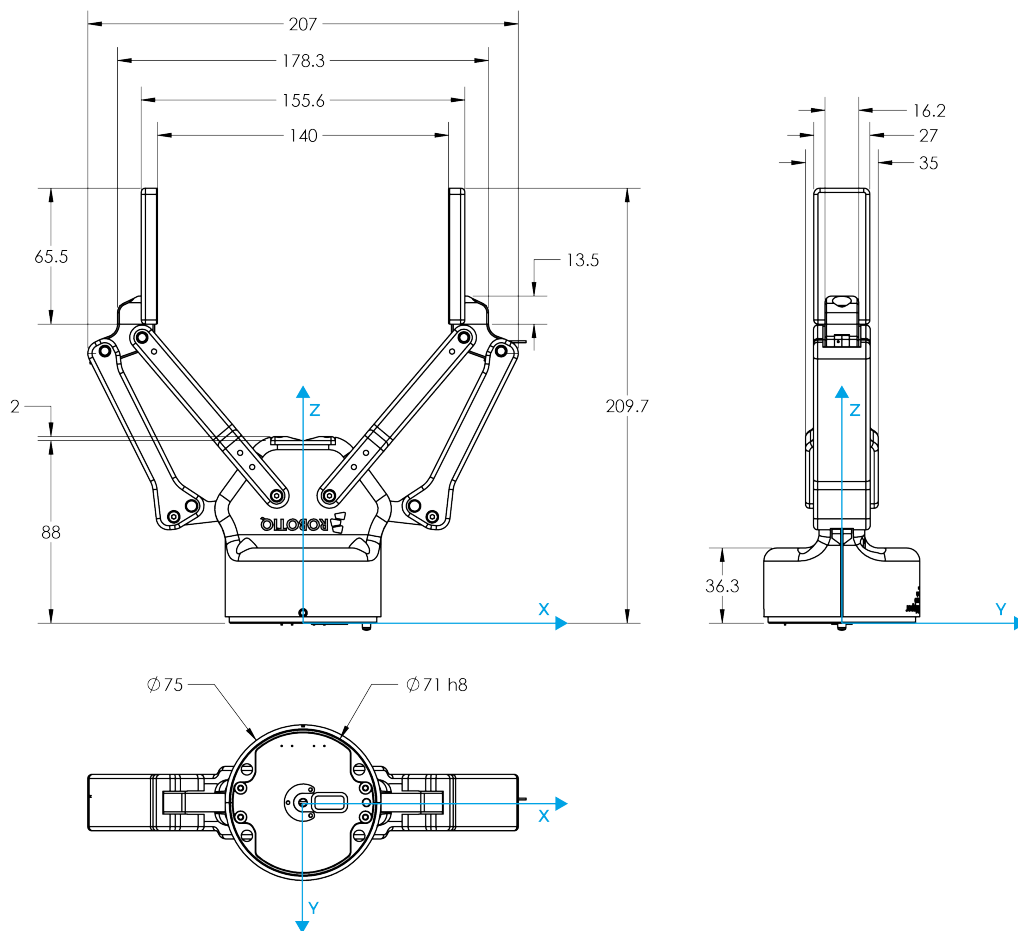

Fig. 5-3: General dimension of 2F-140 (opened).



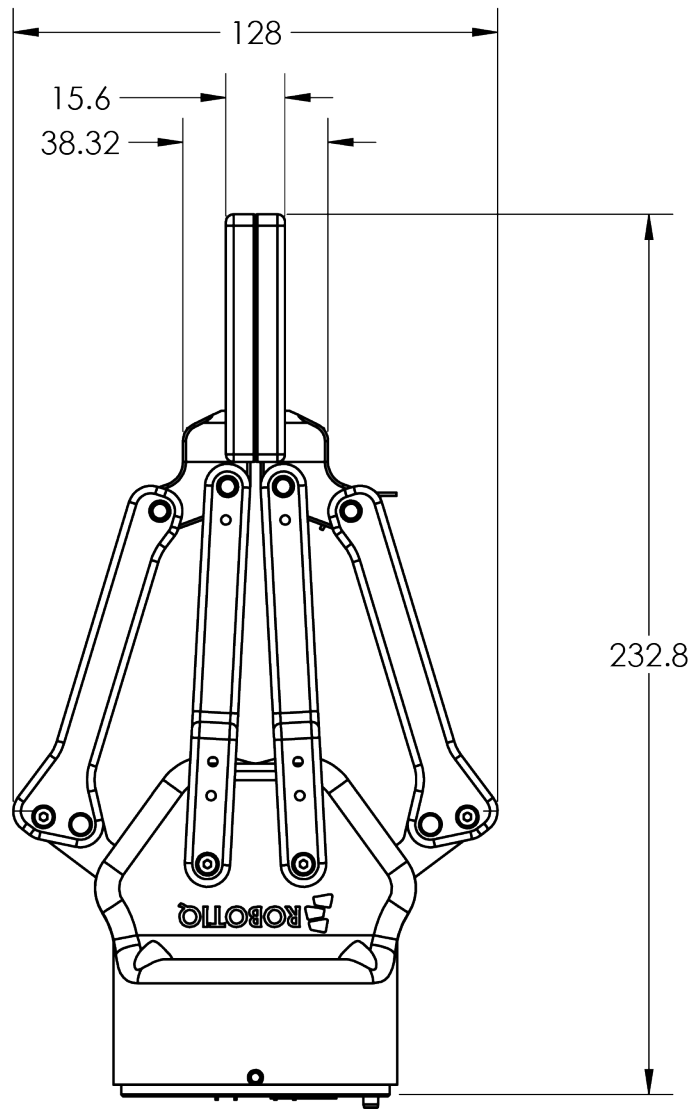

Fig. 5-4: 2F-140 dimensions (closed).

The height and width of the fingers vary with opening position. Fig. 5-3 represents the 2F-140 Gripper in the opened position (position request = 0), while Fig. 5-4 represents the 2F-140 Gripper in the closed position (position request = 255).

5.1.2. Couplings

The 2-Finger Adaptive Gripper requires a coupling provided by Robotiq to operate. The coupling is mandatory since it integrates electronics and electrical contacts.

Info

The coupling is common to both the 2F-85 and the 2F-140.

Coupling for ISO 9409-1-50-4-M6

Bolt pattern for couplings GRP-CPL-062 and GRP-ES-CPL-062 (refer to the **Spare Parts, Kits and Accessories** section) is compatible with:

- 50 mm pitch circle diameter :
 - (4) M6-1.0 low head socket cap screw clearance
 - (1) M6 dowel pin
 - ISO 9409-1 standard 50-4-M6

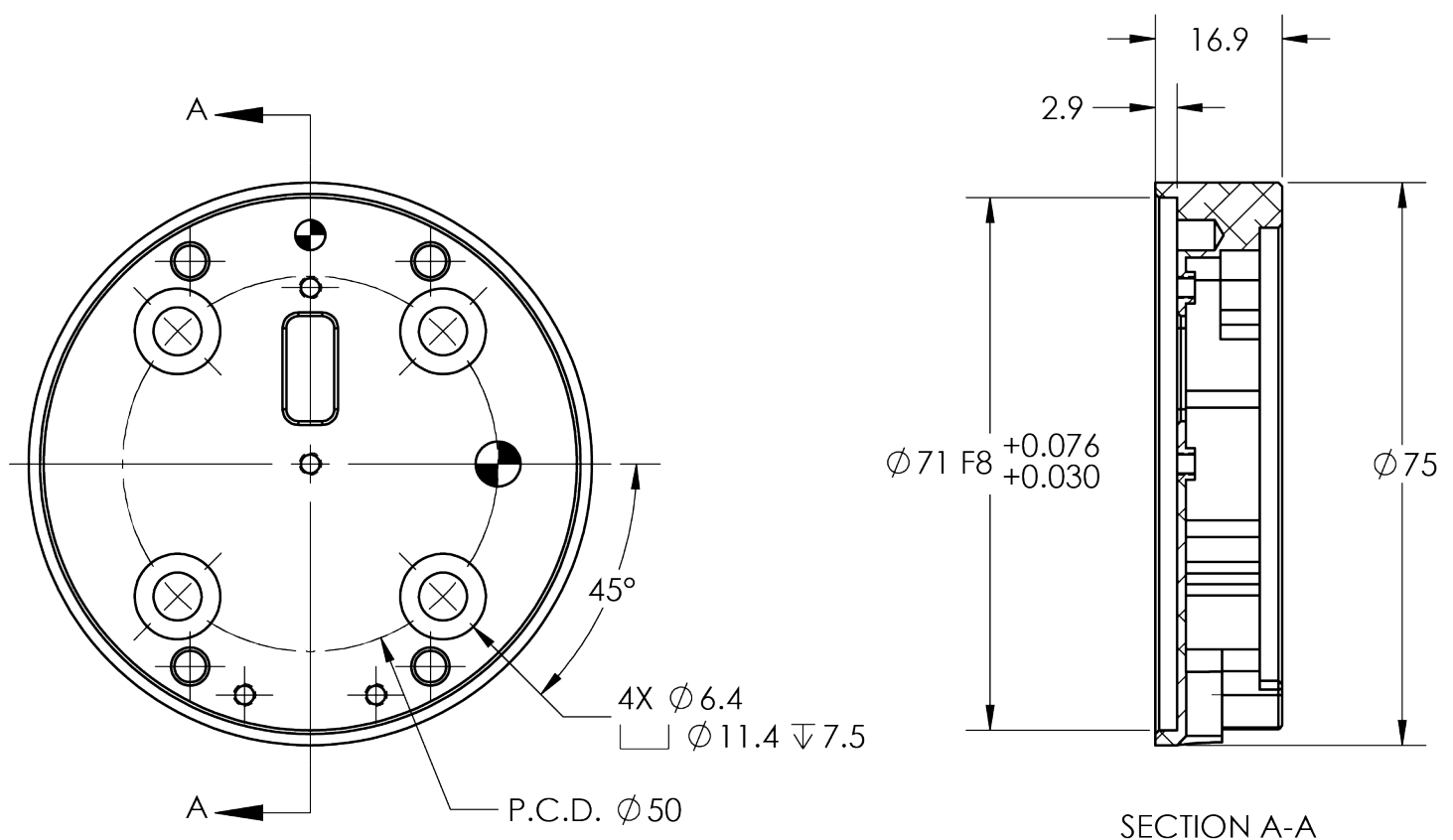

Fig. 5-5: Coupling for ISO 9409-1-50-4-M6.



5.1.3. Fingertips

The contact grip points for the Robotiq 2-Finger Adaptive Gripper are its two fingertips and palm pad.

Robotiq offers a selection of fingertips (see the **Spare Parts, Kits and Accessories** section) and users can create custom fingertips. The figure below represents the distal phalanx (which acts as the fingertip holder). This part is the permanent, non customizable part of the gripper finger on which the fingertip must be mounted.

Custom fingertip designs must meet the following specifications:

- Fingertip must not exceed 100 mm in height from the fingertip's base.
- Fingertip must not exceed 100 mm in width from the fingertip's base (refer to Y axis from Fig. 5-15).
- Refer to the **Mechanical specifications** section to evaluate the grip force according to your fingertip design.
- Applied forces to the gripper must not exceed moment and force limits detailed in the **Moment and Force Limits** section.

Info

Both 2-Finger 85 and 2-Finger 140 use the same finger holder.

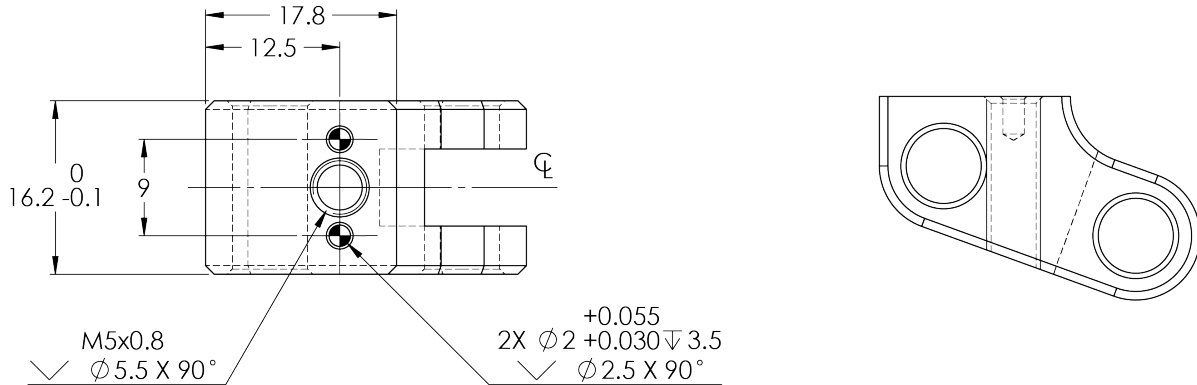

Fig. 5-6: Distal phalanx for holding standard or custom fingertips.

Tip

Custom fingertips will still be subject to the equilibrium line rule for proper actuation of the gripper, see **Object picking** section.



Flat Rubber (NBR) Overmolded Fingertip

The figure below represents a flat rubber (NBR) overmolded fingertip (AGC-TIP-MLD-KIT-85 for 2F-85 and AGC-TIP-MLD-KIT-140 for 2F-140). For details, see the **Spare Parts, Kits and Accessories** section.

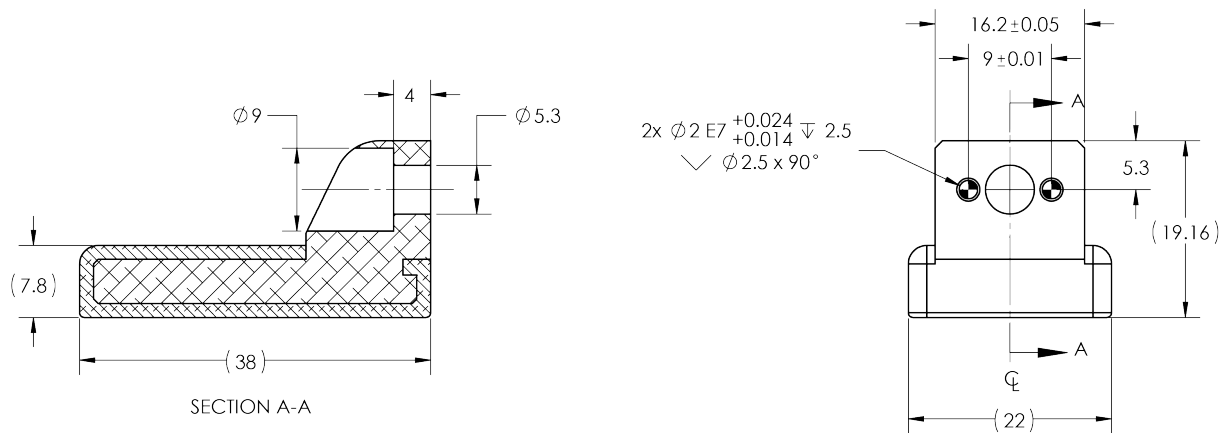

Fig. 5-7: Flat Rubber (NBR) Overmolded Fingertip for 2F-85

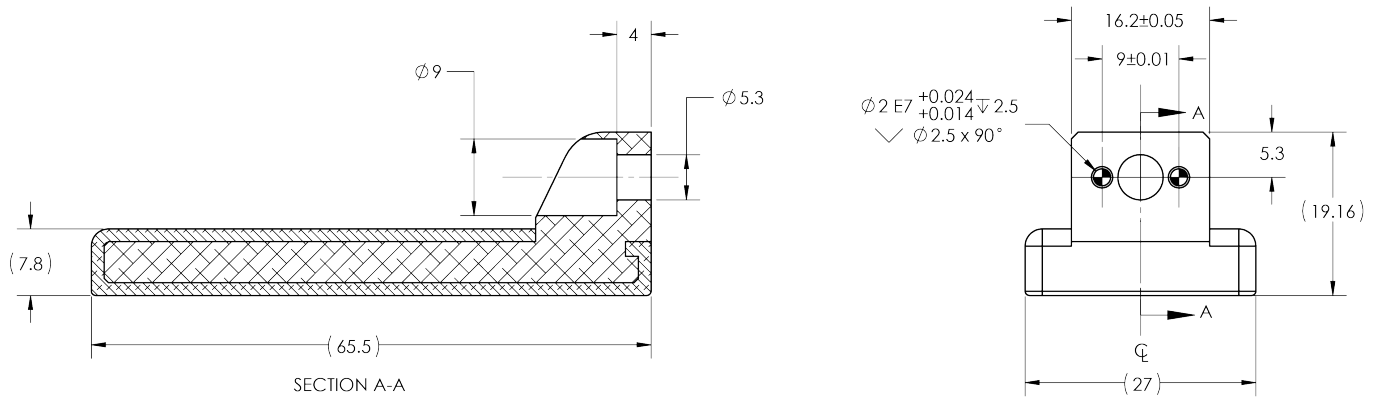

Fig. 5-8: Flat Rubber (NBR) Overmolded Fingertip for 2F-140



Grooved fingertip

The figure below represents the available grooved fingertip **AGC-TIP-205-085** (2-Finger 85) and **AGC-TIP-421-140** (2-Finger 140); please refer to the **Spare Parts, Kits and Accessories** section. This fingertip inner surface has vertical grooves, making ideal for picking cylindrical parts.

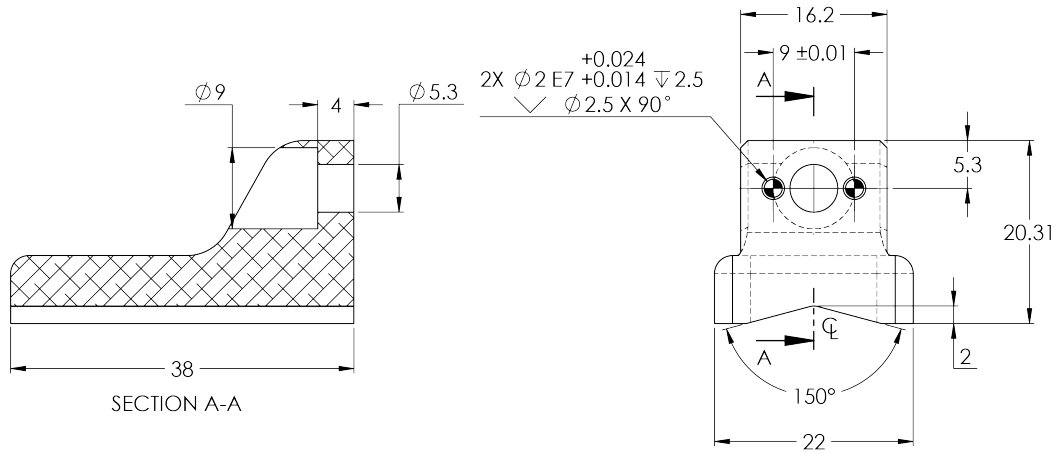

Fig. 5-9: Grooved fingertip AGC-TIP-205-085

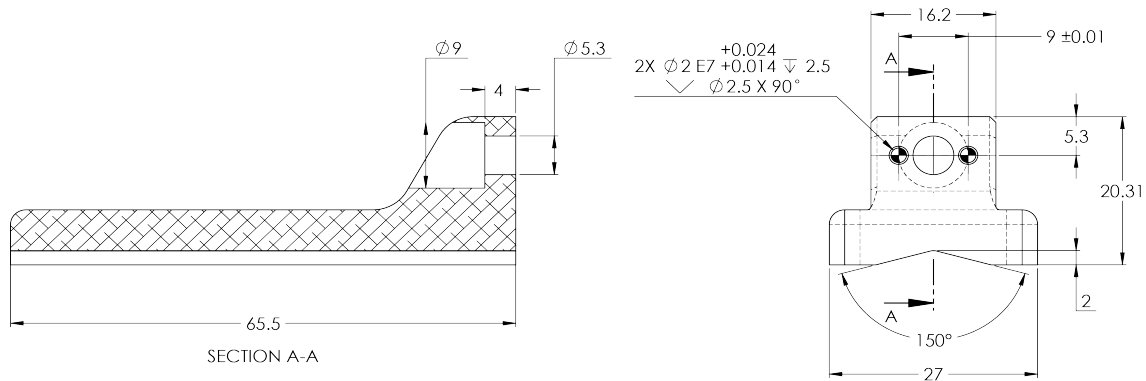

Fig. 5-10: Grooved fingertip AGC-TIP-421-140

5.2. Mechanical specifications

Info

Data shown in the table below is typical for new products, and will vary with use.

Specification	2-FINGER 85		2-FINGER 140	
	Metric Units	Imperial Units	Metric Units	Imperial Units
Stroke	85 mm	3.35 in	140 mm	5.5 in
Minimum object diameter (for encompassing)	43 mm	1.69 in	90 mm	3.5 in
Maximum height	162.8 mm	6.4 in	232.8 mm	9.15 in
Maximum width	148.6 mm	5.85 in	202.1 mm	8.0 in
Weight	925 g	2.04 lbs	1,025 g	2.25 lbs
Grasp Force	20 to 235 N	4.5 to 52.8 lbf	10 to 125 N	2.2 to 28.1 lbf
Finger speed	20 to 150 mm/s	0.8 to 5.9 in/s	30 to 250 mm/s	1.2 to 9.8 in/s
Position repeatability ¹	0.05 mm	0.002 in	0.08 mm	0.003 in
Force repeatability	+/- 10%			
Position resolution ²	0.4 mm	0.016 in	0.6 mm	0.022 in
Grasp force resolution	Maximum force calculation below; refer to the Force Control section			

Table 5-1: Mechanical specifications of the Robotiq 2-Finger 85 and 140 Adaptive Grippers fitted with coupling GRP-CPL-062 and fingertip AGC-TIP-MLD-KIT-85 (2-Finger 85) or AGC-TIP-MLD-KIT-140 (2-finger 140)

¹Repeatability is defined as the positional deviation resulting from the average displacement determined when picking an object with a parallel grasp using standard NBR overmolded fingertips. For more details see the blog.robotiq.com article on repeatability. Position repeatability varies depending on the product wear and operating conditions. The presented values are typical for the newly-manufactured products.

²Resolution is the increment modified from a 1 bit difference of position/speed/force request (from 0 to 255).



5.2.1. Payload and force

Friction Grip payload equation:

$$W = \frac{2FC_f}{S_f}$$

Where:

- W is payload weight
- F is the force applied by the gripper to the load
- C_f is the friction coefficient between fingertip and part load
- S_f is a safety factor to be determined by the robot integrator

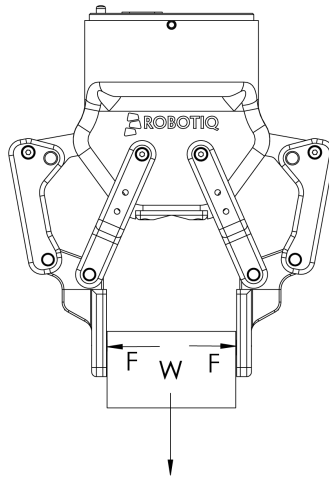

Fig. 5-11: Grasping force on 2-Finger 85 fingertips.

Info

- The Gripper is self-locking.

Info

For example, if the NBR overmolded fingertips **AGC-TIP-MLD-KIT-85** are used to lift a lubricated steel part (machine tending with cutting oils), the friction coefficient would be 0.3 (tested static coefficient of friction).

The maximum weight with a safety factor of 2.4 using the maximum grasping force of 130 N would be :

$$W = (2 \times 130 \text{ N} \times 0.3) / 2.4 = 32.5 \text{ N}$$

This calculation means that a 3.3 kg part will be held by the gripper when not moving (standing still). When accelerating, the payload will decrease.

The biggest factor in such calculations will always be the **friction coefficient**, we recommend testing the coefficient.

Warning

In payload calculations, take **robot acceleration** into account
Robot emergency stops will lead to major deceleration velocities.



Friction grasp and form-fit grasp

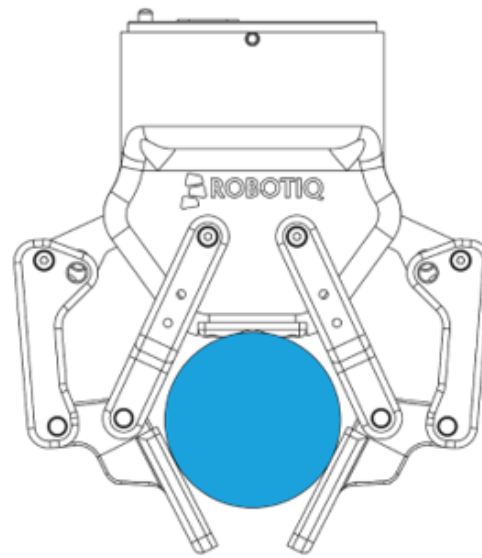
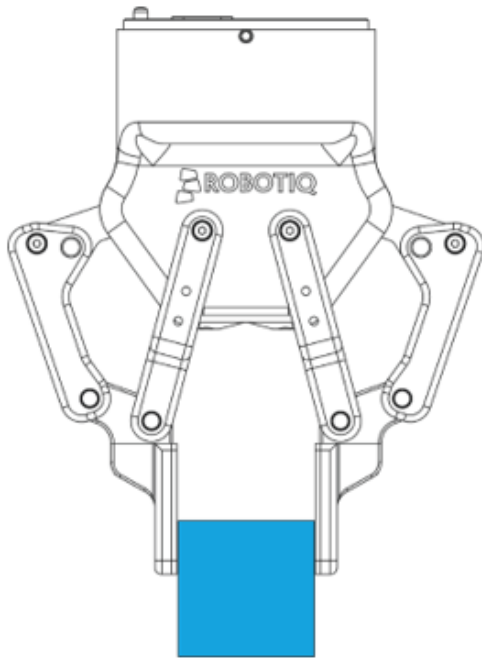

Maximum payload by grasp type

Grasp Type	2F-85	2F-140
Friction grasp	5 kg	2.5 kg
Form-fit grasp	5 kg	2.5 kg



5.2.2. Equilibrium Line

Equilibrium line position (explained in the **General Presentation** section) is detailed in the figure below, where:

- θ is the opening angle between the gripper proximal bar and center line
- D is the distance between the bottom of the fingertips and the equilibrium line as seen on the Z axis in Fig. 1-5.

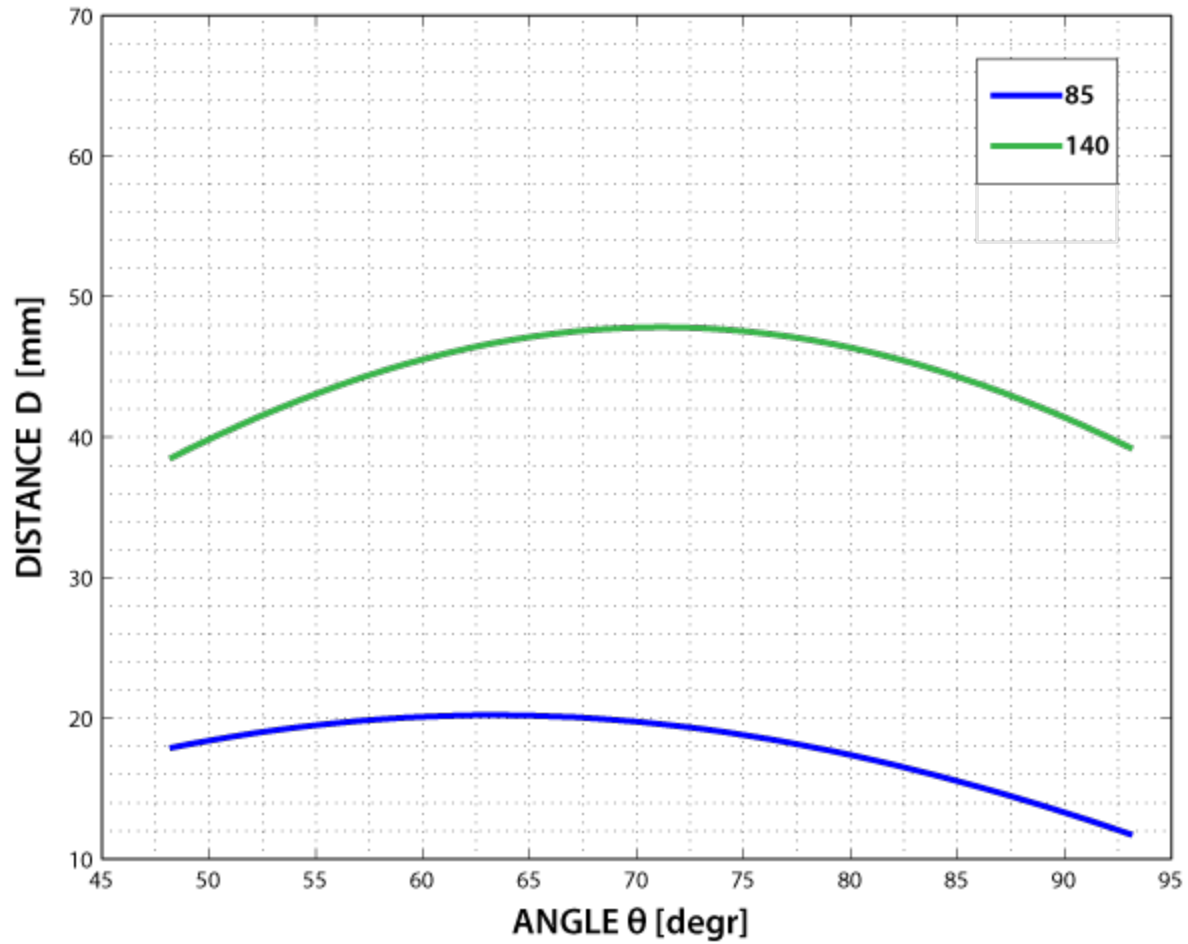

Fig. 5-12: Position of the Gripper equilibrium line according to the opening angle for 2-Finger 85 and 2-Finger 140 options.



5.2.3. Center of mass, tool center point and moment of inertia

When grippers are not mounted on the Wrist Camera, a coupling is included. A dual gripper adapter plate is included when required.

Products	Center of mass (mm)			TCP (mm)						Mass (g)
	X	Y	Z	Gripper 1			Gripper 2			
				X	Y	Z	X	Y	Z	
FT Sensor	-3.0	0.0	17.0	0.0	0.0	37.5	-	-	-	300.0
Camera	-3.0	4.5	9.0	0.0	0.0	23.5	-	-	-	245.0
2F-85	0.0	0.0	58.0	0.0	0.0	174.0	-	-	-	925.0
2F-140	0.0	0.0	73.0	0.0	0.0	244.0	-	-	-	1025.0
Hand-E	0.0	0.0	57.5	0.0	0.0	157.0	-	-	-	1090.0
Dual grippers plate	0.0	0.0	15.5	-	-	-	-	-	-	265.0
FT Sensor + 2F-85	-0.7	0.0	76.3	0.0	0.0	211.5	-	-	-	1225.0
FT Sensor + 2F-140	-0.7	0.0	89.3	0.0	0.0	281.5	-	-	-	1325.0
FT Sensor + Hand-E	-0.6	0.0	78.2	0.0	0.0	194.5	-	-	-	1390.0
Camera + 2F-85	-0.7	1.2	57.1	0.0	0.0	175.5	-	-	-	975.0
Camera + 2F-140	-0.7	1.1	72.4	0.0	0.0	246.5	-	-	-	1075.0
Camera + Hand-E	-0.6	1.0	57.4	0.0	0.0	159.5	-	-	-	1135.0
FT Sensor + Camera + 2F-85	-1.3	0.9	76.3	0.0	0.0	213.0	-	-	-	1275.0
FT Sensor + Camera + 2F-140	-1.2	0.8	89.6	0.0	0.0	284.0	-	-	-	1375.0
FT Sensor + Camera + Hand-E	-1.1	0.8	78.6	0.0	0.0	197.0	-	-	-	1435.0
Hand-E/Hand-E	0.0	0.0	62.0	154.0	0.0	138.0	-154.0	0.0	138.0	2445.0
Hand-E/2F-85	5.9	0.0	61.7	154.0	0.0	138.0	-166.0	0.0	150.0	2280.0
Hand-E/2F-140	-2.4	0.0	66.6	154.0	0.0	138.0	-215.5	0.0	199.5	2380.0
2F-85/2F-85	0.0	0.0	61.4	166.0	0.0	150.0	-166.0	0.0	150.0	2115.0
2F-85/2F-140	-8.7	0.0	66.6	166.0	0.0	150.0	-215.5	0.0	199.5	2215.0
2F-140/2F-140	0.0	0.0	71.4	215.5	0.0	199.5	-215.5	0.0	199.5	2315.0
Camera + Hand-E/Hand-E	-0.3	0.4	78.5	154.0	0.0	161.5	-154.0	0.0	161.5	2690.0
Camera + Hand-E/2F-85	5.0	0.4	77.8	154.0	0.0	161.5	-166.0	0.0	173.5	2525.0
Camera + Hand-E/2F-140	-2.5	0.4	82.5	154.0	0.0	161.5	-215.5	0.0	223.0	2625.0
Camera + 2F-85/2F-85	-0.3	0.5	77.0	166.0	0.0	173.5	-166.0	0.0	173.5	2360.0
Camera + 2F-85/2F-140	-8.1	0.4	82.1	166.0	0.0	173.5	-215.5	0.0	223.0	2460.0
Camera + 2F-140/2F-140	-0.3	0.4	86.7	215.5	0.0	223.0	-215.5	0.0	223.0	2560.0
FT Sensor + Hand-E/Hand-E	-0.3	0.0	90.5	154.0	0.0	175.5	-154.0	0.0	175.5	2745.0
FT Sensor + Hand-E/2F-85	4.9	0.0	89.7	154.0	0.0	175.5	-166.0	0.0	187.5	2580.0
FT Sensor + Hand-E/2F-140	-2.5	0.0	94.3	154.0	0.0	175.5	-215.5	0.0	237.0	2680.0
FT Sensor + 2F-85/2F-85	-0.4	0.0	88.8	166.0	0.0	187.5	-166.0	0.0	187.5	2415.0
FT Sensor + 2F-85/2F-140	-8.0	0.0	93.7	166.0	0.0	187.5	-215.5	0.0	237.0	2515.0
FT Sensor + 2F-140/2F-140	-0.3	0.0	98.4	215.5	0.0	237.0	-215.5	0.0	237.0	2615.0
FT Sensor + Camera + Hand-E/Hand-E	-0.5	0.4	106.1	154.0	0.0	199.0	-154.0	0.0	199.0	2990.0
FT Sensor + Camera + Hand-E/2F-85	4.2	0.4	104.9	154.0	0.0	199.0	-166.0	0.0	211.0	2825.0
FT Sensor + Camera + Hand-E/2F-140	-2.5	0.4	109.4	154.0	0.0	199.0	-215.5	0.0	260.5	2925.0
FT Sensor + Camera + 2F-85/2F-85	-0.6	0.4	103.5	166.0	0.0	211.0	-166.0	0.0	211.0	2660.0
FT Sensor + Camera + 2F-85/2F-140	-7.6	0.4	108.4	166.0	0.0	211.0	-215.5	0.0	260.5	2760.0
FT Sensor + Camera + 2F-140/2F-140	-0.6	0.4	112.9	215.5	0.0	260.5	-215.5	0.0	260.5	2860.0



Info

The angle to calculate the TCP for grippers mounted on a dual gripper assembly is as follows:

- $R_x = 0$
- $R_{y+}/R_{y-} = 0.7854$
- $R_z = 0$

The moment of inertia are calculated for a configuration where the fingers are fully open. Here is the approximate moment of inertia matrix for the gripper:

2-FINGER 85 OPTION

$$I = \begin{bmatrix} I_{XX} & I_{XY} & I_{XZ} \\ I_{YX} & I_{YY} & I_{YZ} \\ I_{ZX} & I_{ZY} & I_{ZZ} \end{bmatrix} = \begin{bmatrix} 4180 & 0 & 0 \\ 0 & 5080 & 0 \\ 0 & 0 & 1250 \end{bmatrix} = \begin{bmatrix} 14.3 & 0 & 0 \\ 0 & 17.4 & 0 \\ 0 & 0 & 4.3 \end{bmatrix}$$

$kg * mm^2$ $lb * in^2$

2-FINGER 140 OPTION

$$I = \begin{bmatrix} I_{XX} & I_{XY} & I_{XZ} \\ I_{YX} & I_{YY} & I_{YZ} \\ I_{ZX} & I_{ZY} & I_{ZZ} \end{bmatrix} = \begin{bmatrix} 7400 & 0 & 0 \\ 0 & 9320 & 0 \\ 0 & 0 & 2260 \end{bmatrix} = \begin{bmatrix} 25.3 & 0 & 0 \\ 0 & 31.8 & 0 \\ 0 & 0 & 7.7 \end{bmatrix}$$

$kg * mm^2$ $lb * in^2$

Fig. 5-13: Inertia matrix for Robotiq 2-Finger .



5.2.4. Moment and Force Limits

The 2-Finger Adaptive Gripper has limits for moment and force values. The maximum moment and force values are independent of the grasp force the gripper applies on its payload. For payload calculation, refer to the **Payload and force** section.

Warning

Always operate within range.

Calculation of maximum moments and forces should include robot accelerations and safety factors.

Parameters	Finger Option	
	2-Finger 85	2-Finger 140
F_x, F_y, F_z	50 N	25 N
M_x^*	5 Nm	5 Nm
M_y^*	5 Nm	5 Nm
M_z	3 Nm	3 Nm

* Moments in x and y are calculated from the base of the fingertips as shown in Fig. 5-15.

Fig. 5-14: Maximum moment and force values

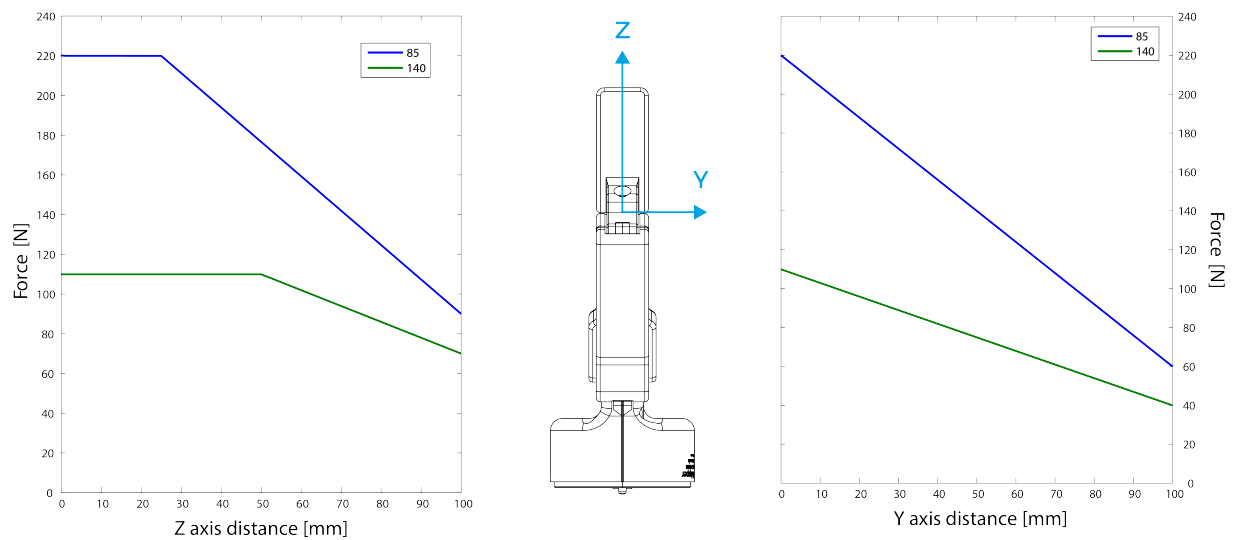

Fig. 5-15: Maximum recommended grip force in the Y and Z axis for the 2-Finger 85 and 2-Finger 140.

Usage example with listed limits :

- After picking its normal payload, the robot can use the 2-Finger 85 Gripper to apply up to 50 N of force in any direction. Applying more than 50 N can damage the gripper or result in payload loss.
- A gripper can pick up a screwdriver and apply 3 Nm of torque to screw (such moment would be applied in the Z axis).



5.3. Electrical specifications

SPECIFICATION	VALUE
Operating supply voltage	24 V DC \pm 10%
Absolute maximum supply voltage	28 V DC
Quiescent power (minimum power consumption)	< 1 W
Peak current	1 A



6. Maintenance

The Adaptive Gripper requires only external maintenance with limited downtime.

Maintenance for both 2-Finger Adaptive Grippers is required after specified usage, measured in time (normal 40h week) or in cycles (see Info box below for details about cycle definition).

Following the maintenance interval will ensure :

- Correct functioning of your gripper.
- Validity of your warranty.
- Proper lifetime for your gripper.

Warning

Unless otherwise indicated, any **repairs** done on the gripper will be performed by Robotiq.

Info

A cycle is defined as a **go to requested position** command that results in grip force being applied (closing the fingers on themselves or picking an object while opening or closing).

Operation	Daily	Weekly	1 M cycles	2 M cycles
Gripper Cleaning	Dirty conditions	Normal conditions		
Periodic Inspection			X	
Fingertip Replacement ¹			X	
Overhaul ²				X

Table 6-1: Maintenance intervals for the 2-Finger Grippers

¹Replace fingertip before if wear is visible.

²Overhaul is recommended after 2M cycles and is done by Robotiq at the user's expense, please contact Robotiq support.

Caution

Always turn off the robot and the gripper power supply before performing any maintenance operations.



Maintenance operations are for the average normal usage of the gripper, the maintenance intervals must be adjusted according to environmental conditions such as:

- Operating temperature
- Humidity
- Presence of chemicals
- Presence of physical parts (debris, scraps, dust, grease etc.)
- Interaction with operated parts (sharp or rough)
- Dynamics of the operation (accelerations)



6.1. Gripper cleaning

Maintenance Interval	Tools You Need	Parts You Need
Weekly or daily in dirty operating conditions	<ul style="list-style-type: none"> Flat head precision 2 mm screwdriver 4 mm hex key Dry tissue or towel 	None (unless damage is detected)

Caution

Always turn off the robot and the gripper power supply before performing any maintenance operations.

Caution

The maintenance operator must be grounded to prevent electrostatic discharge that could damage the gripper electronics.

Caution

The Robotiq 2-Finger Adaptive Gripper is not waterproof or water resistant without additional protection, only clean the gripper with a dry towel.

- 1 Remove the gripper from its coupling using the 4 mm hex key to unscrew the four (4) M5-0.8 x 25mm screws. Note that each screw uses a tooth lock washer, do not lose them.
- 2 Use the flat head precision screwdriver to open or close the gripper by turning the flat head screw located under the gripper, where the coupling connects (illustrated in the figure below).
 - a Open or close to access the palm pad and other parts of the gripper.
- 3 Clean the gripper with a dry towel, remove all debris, dirt and dust from the surface of the gripper, clean all fingertips, dry thoroughly.
- 4 Clean the coupling with a dry towel, pay particular attention to the electrical contact.
- 5 Visually inspect the gripper and pay attention to any visible damage.
- 6 Put the gripper back on and secure it with the four (4) M5-0.8 x 25mm screws and tooth lock washers.

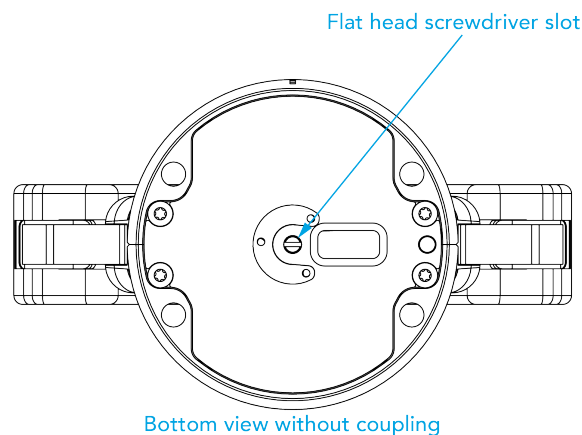

Fig. 6-1: Flat head screwdriver slot for manual opening and closing of the Gripper.



6.2. Periodic inspection

Maintenance Interval	Tools You Need	Parts You Need
Monthly	<ul style="list-style-type: none"> • Flat head precision 2 mm screwdriver • 4 mm hex key • Dry tissue or towel 	None (unless damage is detected)

Caution

Always turn off the robot and the gripper power supply before performing any maintenance operations.

- 1 Remove and clean the gripper following instructions in the **Gripper cleaning** section.
- 2 Inspect the gripper :
 - a Finger movement must be symmetric and fluid:
 - i. Test the return movement by pushing fingers open, the fingers must come back to the initial starting position on its own.
 - ii. Test the general movement of the fingers by turning the flat head screw under the gripper (see Fig. 6-1).
 - b Fingertip wear must not affect gripping, if wear is visible and affects movement, change accordingly (refer to the **Gripper cleaning** section).
 - c Check for any collision damage, if damage is visible, contact support@robotiq.com.
 - d Check for any sign of wear on the gripper chassis, if wear is present and may affect the gripper, contact support@robotiq.com.
- 3 Put back in place respecting instructions from the **Gripper cleaning** section.



6.3. Fingertip replacement

Maintenance Interval	Tools You Need	Parts You Need
1 Million cycles or when wear is visible	<ul style="list-style-type: none"> • 4 mm hex key • Dry tissue or towel • Low strength thread locker 	2 x Robotiq 2-Finger Adaptive Gripper fingertip (overmolded or V-grooved).

Refer to the **Spare Parts, Kits and Accessories** section to order Robotiq 2-Finger Adaptive Gripper replacement parts.

Caution

Always turn off the robot and the gripper power supply before performing any maintenance operations.

- 1 Remove and clean the gripper following instructions from the **Gripper cleaning** section.
- 2 Remove the worn fingertip by removing the M5 screw with the 4 mm hex key; make sure not to mislay the 2 mm dowel pins.
- 3 Clean the fingertip holder and dry thoroughly.
- 4 Insert the new fingertip by inserting the dowel pins in the fingertip holder.
- 5 Secure the fingertip using the provided M5 screw, apply low strength threadlocker to the M5 screw threads.
- 6 Repeat for remaining finger.



6.4. Overhaul

Maintenance Interval	Tools You Need	Parts You Need
2 Million cycles or at warranty expiration	None	None

Gripper overhaul is necessary when the gripper reaches 2 Million cycles or when warranty expires. Overhaul is done by Robotiq, please contact Robotiq support service.

Gripper overhaul includes, but is not limited to :

- Worn parts changed
 - Power transmission gearing mechanism
 - Plain bearings
 - Ball bearings
- Quality control
 - Specification test (force, speed, position)

Overhaul takes a maximum of 5 business days after reaching Robotiq, shipping is at customer's expense.

Tip

Loan units are available while your gripper is under maintenance.



7. Spare Parts, Kits and Accessories

The following list is up to date at print time and is subject to change, check online for updates.

Info

Unless specified, screws, dowel pins and other hardware are only included for the grippers, and not for robots.

Item	Description	Ordering Number (2-Finger 85)	Ordering Number (2-Finger 140)
Gripper basic unit	Adaptive Gripper 2-Finger basic unit with fingers (no fingertip, no coupling)	AGC-GRP-2F85	AGC-GRP-2F140
Kit for AUBO	Gripper basic unit with NBR overmolded fingertips, 10 m cable and coupling for AUBO Series Robot	AGC-AUBO-KIT-85	AGC-AUBO-KIT-140
Controller	Optional controller for industrial communications. See Robotiq Universal Controller manual for more information.	UNI-CTR-XXXX	
Finger Kit	Finger upgrade kit for 85 or 140 mm option. Included: <ul style="list-style-type: none"> • 2 x Replacement finger • 2 x Hardware kit • 1 x hex key 	AGC-FIN-KIT-85-V4	AGC-FIN-KIT-140-V4
10m Device cable	10 m Robotiq device cable for power and communication. Straight M12 5-pins female on one side, single ended on the other, shielded	CBL-COM-2065-10-HF	
USB to RS485 adapter	USB to RS485 adapter, can be used with device cable for USB connection	ACC-ADT-USB-RS485	
Flat overmolded fingertip kit	<ul style="list-style-type: none"> • 2 x flat overmolded fingertips. • 4 x dowel pins M2 x 6 mm • 2 x M5-0.8 x 10 mm SHCS 	AGC-TIP-MLD-KIT-85	AGC-TIP-MLD-KIT-140
Grooved fingertips	<ul style="list-style-type: none"> • 2 x V-grooved fingertips 	AGC-TIP-205-085	AGC-TIP-421-140



Item	Description	Ordering Number (2-Finger 85)	Ordering Number (2-Finger 140)
	<ul style="list-style-type: none"> • 2 x M5-0.8 x 10 mm SHCS • 4 x dowel pins M2 x 6 mm 		
Replacement finger	<ul style="list-style-type: none"> • 1 x finger • 4 x screws M3-0.5 X 5 LHCS • 1 x proximal locking shaft • 1 x parallel locking shaft 	AGC-FIN-085	AGC-FIN-140
Finger protector	<ul style="list-style-type: none"> • 2 x protector • 8 x M3 screws 	AGC-PRO-KIT-V4	AGC-PRO-KIT-140
Parallel locking shaft	<ul style="list-style-type: none"> • 2 x parallel locking shafts • 4 x M3-0.5 x 5 mm LHCS 	AGC-PARA-KIT	
Fingertip conversion Kit	<ul style="list-style-type: none"> • 2 x Fingertip adapters • 1 x Screw Kit 	AGC-TIP-CONV-KIT	



To install the 2-Finger Gripper on a robot that has a different bolt pattern than part GRP-CPL-062 (ISO 9409-1-50-4-M6), you can use one of the following. The couplings and adapter plates listed below fit with both the 2-Finger Gripper and Hand-E.

Item	Description	Ordering Number
Blank coupling	Blank coupling for Adaptive Gripper 2-Finger, with screws for Gripper fixation and 1 m pigtail cable	GRP-CPL-BLANK
ISO-9409-1-50-4-M6 coupling (coupling-to-wrist)	ISO 9409-1-50-4-M6 coupling for 2-Finger Grippers, with screws for Gripper fixation	GRP-ES-CPL-062
ISO 9409-1-50-4-M6 coupling (coupling to controller)	ISO 9409-1-50-4-M6 coupling for 2-Finger Grippers, with screws for Gripper fixation and 1 m pigtail cable	GRP-CPL-062
ISO 9409-1-31.5-4-M5 coupling	ISO 9409-1-31.5-4-M5 coupling for Adaptive Gripper 2-Finger, with screws for Gripper fixation and 1 m pigtail cable	GRP-CPL-063
ISO 9409-1-40-4-M6 coupling	ISO 9409-1-40-4-M6 coupling for Adaptive Gripper 2-Finger, with screws for Gripper fixation and 1 m pigtail cable	GRP-CPL-064
56-8M4-1D4 coupling	Coupling for 56 mm PCD ¹ with (8) M4 and (1) 4mm dowel pin, with screws for 2-F Gripper fixation and 1 m pigtail cable	AGC-CPL-065-002
56-6M4-1D6 coupling	Coupling for 56 mm PCD ¹ with (6) M4 and (1) 6mm dowel pin, with screws for 2-F Gripper fixation and 1 m pigtail cable	AGC-CPL-066-002
60-4Ø5-1D5 coupling	Coupling for 60 mm PCD ¹ with (4) M5 thread and (1) 5mm dowel pin, with screws for 2-F Gripper fixation and 1 m pigtail cable	AGC-CPL-067-002
63-6M6-2D6 coupling	Coupling for 63 mm PCD ¹ with (6) M6 and (2) 6mm dowel pins, with screws for 2-F Gripper fixation and 1 m pigtail cable	AGC-CPL-068-002
40-4M5-1D3 coupling	Coupling for 40 mm PCD ¹ with (4) M5 and (1) 3mm dowel pins, with screws for 2-F Gripper fixation and 1 m pigtail cable	AGC-CPL-070-002
31.5-4M4 coupling	Coupling for 31.5 mm PCD ¹ with (4) M4, with screws for 2-F Gripper fixation and 1 m pigtail cable	AGC-CPL-071-002
Adapter plate to 63-4M6-71-2D3	Wrist adapter plate for use with AGC-CPL-064-002. Interface to 63 mm PCD ¹ with (4) M6 screws and 71 mm PCD ¹ with (2) M3 dowel pins	AGC-APL-151-002
Adapter plate to 63-4M6-61_4-2D6	Wrist adapter plate for use with AGC-CPL-064-002. Interface to 63 mm PCD ¹ with (4) M6 screws and 61.4 mm PCD ¹ with (2) M6 dowel pins	AGC-APL-152-002



Adapter plate to
80-6M8-2D82D8

Wrist adapter plate for use with AGC-CPL-064-002. Interface to 80 mm PCD¹
with (6) M8 screws and (2) M8 dowel pins

AGC-APL-153-002

¹Pitch Circle Diameter

Tip

For legacy part replacement visit the documentation archives and the appropriate manual or consult your Robotiq distributor.



8. Troubleshooting

8.1. Using the Robotiq User Interface (RUI)

Use the Robotiq User Interface to check that your gripper functions properly:

1. Install the Robotiq User Interface on a computer.
2. Connect your gripper to a computer USB port.
3. Send instructions to your gripper via the Robotiq User Interface. If this fails, check that all cables are connected to your gripper and to your computer.
4. Contact support@robotiq.com.

Info

For details on the Robotiq User Interface, see its Instruction Manual, available on robotiq.com/support.



9. Warranty and Patent

Robotiq warrants the 2F-85 and 2F-140 Adaptive Robot Grippers against defects in material and workmanship for a period of one year from the date of reception when utilized as intended. Robotiq also warrants that this equipment will meet applicable specifications under normal use.

Warranty applies under the following conditions:

- Usage respects the operating and storage conditions specified in the **Environmental and Operating Conditions** section
- Proper installation of the Gripper specified in **Installation** section and the following subsections.
- Until one of these condition is reached:
 - 1 year
 - 2 000 000 cycle count¹
- Usage respects maintenance specified in the **Maintenance** section.
- Usage respects recommended payload and force specified in the **Payload and force** section.

¹Cycle count: One (1) cycle is defined as an object picking attempt, successful or not (open or closing onto an object, or closing on itself). It is calculated in the internal memory of the 2-Finger Adaptive Gripper and can be seen with the Robotiq User Interface.

During the warranty period, Robotiq will repair or replace any defective 2-Finger Adaptive Robot Gripper, as well as verify and adjust the Gripper free of charge if the equipment should need to be repaired or if the original adjustment is erroneous. If the equipment is sent back for verification during the warranty period and found to meet all published specifications, Robotiq will charge standard verification fees.

The unit is considered defective when at least one of the following conditions occurs :

- The Gripper fingers cannot close or open;
- The Gripper feedback necessary for the robot program is not accessible.

Parts that come into contact with the work piece and wearing parts such as the finger and palm pads are not covered by the warranty.

Caution

The warranty will become null and void if :

- The unit has been tampered with, repaired or worked on by unauthorized individuals.
- The warranty sticker has been removed (if present)
- The screws, other than as explained in this guide, have been removed.
- The unit has been opened other than as explained in this guide.
- Unit serial number has been altered, erased, or removed.
- Unit has been misused, neglected, or damaged by accident.

This warranty is in lieu of all other warranties expressed, implied, or statutory, including, but not limited to, the implied warranties of merchantability and fitness for a particular purpose. In no event shall Robotiq be liable for special, incidental, or consequential damages.



Robotiq shall not be liable for damages resulting from the use of the Robotiq 2-Finger Adaptive Robot Gripper, nor shall Robotiq be responsible for any failure in the performance of other items to which the 2-Finger Adaptive Robot Gripper is connected or the operation of any system of which the Gripper may be a part.

Exclusions

This warranty excludes failure resulting from: improper use or installation, normal wear and tear, accident, abuse, neglect, fire, water, lightning or other acts of nature, causes external to the Gripper or other factors beyond Robotiq's control.

Robotiq reserves the right to make changes in the design or construction of any of its products at any time without incurring any obligation to make any changes whatsoever on units already purchased.

Patent

This product incorporates technology developed by Lionel Birglen, professor at Polytechnique Montreal, and is used under license of Polyvalor LP.



10.2. Applied standards

This section describes all applied harmonized standards for the design and production of the Robotiq 2-Finger Adaptive Gripper. Standards are applied where applicable, some points may not be applied if not applicable to this specific product. Conformity is not enforced by any laws, it is self-applied and the aim is to define normal safety and performance requirements for similar products.

Caution

Conformity of the product is only met if all instructions of this manual are followed. Among others; installation, safety measures and normal usage must be met.

The following standards have been applied:

NF EN ISO 14539	2000	Manipulating industrial robots — Object handling with grasp-type grippers — Vocabulary and presentation of characteristics
NF EN ISO 12100	2010	Safety of machinery — General principles for design — Risk assessment and risk reduction
NF EN IEC 60204-1	2006	Safety of machinery — Electrical equipment of machines — Part 1: General requirements



11. Contact

www.robotiq.com

Contact Us

Phone

1-888-ROBOTIQ (762-6847)
(+1) 418-380-2788 Outside US and Canada

Technical support

Extension 3

Sales

Extension 2

Head office

Robotiq:
966, chemin Olivier
Suite 500
St-Nicolas, Québec
G7A 2N1
Canada



Where automation Pros come to share their know-how and get answers.

dof.robotiq.com

